

## PROTEASOMES IN THE ARCHAEA: FROM STRUCTURE TO FUNCTION

Julie A. Maupin-Furlow, Heather L. Wilson, Steven J. Kaczowka, and Mark S. Ou

Department of Microbiology and Cell Science, University of Florida, Gainesville, FL 32611-0700

### TABLE OF CONTENTS

1. Abstract
2. Introduction
3. Proteasomes and the 20S proteolytic core
  - 3.1. Architecture of the 20S proteasome
  - 3.2. Catalytic mechanism of peptide bond hydrolysis
  - 3.3. Distribution and subunit composition of 20S proteasomes
  - 3.4. Assembly of 20S proteasomes
4. Proteasome-associated AAA<sup>+</sup> ATPases
  - 4.1. AAA<sup>+</sup> superfamily
  - 4.2. Rpt (AAA<sup>+</sup>) subunits of eucaryal 26S proteasomes
  - 4.3. Archaeal proteasome-activating nucleotidase (PAN)
  - 4.4. Eubacterial AAA ATPase-forming ring-shaped complexes (ARC)
  - 4.5. Chaperone activity of AAA<sup>+</sup> proteins
5. Substrate targeting and signal recognition
  - 5.1. Ubiquitin-dependent
  - 5.2. Ubiquitin-independent
6. Archaeal genomics
  - 6.1. 20S proteasome and PAN operons
  - 6.2. Additional energy-dependent proteases
    - 6.2.1. Rpt/FtsH ATPase
    - 6.2.2. Lon protease
    - 6.2.3. Clp ATPase and HtrA (DegP)
7. Role of proteasomes in stress responses
  - 7.1. Eucaryal 26S proteasome and stress
  - 7.2. Eubacterial HslUV proteases and stress
  - 7.3. Prokaryotic 20S proteasomes and AAA<sup>+</sup> proteins and stress
8. Perspective
9. Acknowledgments
10. References

### 1. ABSTRACT

Survival of cells is critically dependent on their ability to rapidly adapt to changes in the natural environment no matter how >extreme= the habitat. An interplay between protein folding and hydrolysis is emerging as a central mechanism for stress survival and proper cell function. In eucaryotic cells, most proteins destined for destruction are covalently modified by the ubiquitin-system and then degraded in an energy-dependent mechanism by the 26S proteasome, a multicatalytic protease. The 26S proteasome is composed of a 20S proteolytic core and 19S cap (PA700) regulator which includes six AAA<sup>+</sup> ATPase subunits. Related AAA<sup>+</sup> proteins and 20S proteasomes are found in the archaea and Gram positive actinomycetes. In general, 20S proteasomes form a barrel-shaped nanocompartment with narrow openings which isolate rather non-specific proteolytic active-sites to the interior of the cylinder and away from interaction with cytosolic proteins. The proteasome-

associated AAA<sup>+</sup> proteins are predicted to form ring-like structures which unfold substrate proteins for entry into the central proteolytic 20S chamber resulting in an energy-dependent and processive destruction of the protein. Detailed biochemical and biophysical analysis as well as identification of proteasomes in archaea with developed genetic tools are providing a foundation for understanding the biological role of the proteasome in these unusual organisms.

### 2. INTRODUCTION

Proteolysis is central to cell function and vital to the ability of cells to adapt to changes in the natural environment. Although most cellular proteins are usually stable, there are specific subsets which display high rates of turnover including those regulating metabolic branch points, transcription, cell division, differentiation, and DNA

repair (1-7). When these high turnover rates are coupled with transcriptional control, cells are able to respond effectively to changes by rapidly altering the concentration of enzymes at specific times and even in certain locations in the cell. Not only are normal proteins specifically targeted for hydrolysis, but abnormal proteins which do not properly fold in the presence of molecular chaperones are also eliminated (8). Abnormal proteins include those which accumulate after exposure to stresses such as heat shock or oxidative damage as well as those which are produced by errors in transcription or translation, genetic mutation, or RNA damage. Also subunits of multi-protein complexes are often targets for degradation when subunit stoichiometry becomes disturbed. Proteases also play an important role in an overall increase in the hydrolysis of most proteins during starvation to replenish the amino acid pool. Surprisingly, all of these degradative functions are primarily mediated by *energy-dependent* proteases even though the hydrolysis of peptide bonds theoretically should not require the input of energy based on thermodynamics (2,9). It is likely that these proteases eliminate the majority of both normal and abnormal proteins in a processive mechanism (10-12), meaning that a protein is completely degraded into peptides without release of intermediates. Thus, cells minimize the accumulation of polypeptide fragments and insoluble protein aggregates which may be lethal and/or function inappropriately in the cell.

Energy-dependent proteases have been identified in all organisms analyzed and, although not universally distributed, include the Lon, FtsH (HflB), ClpAP, ClpXP, HslUV (ClpYQ), and proteasome complexes (13,14). Inhibition or modification of the levels of many of these energy-dependent proteases disrupts the normal heat shock response (*e.g.* 15). Several of these proteases are stress or heat shock inducible including ClpXP (16,17), Lon (18-20), FtsH (20,21), HslUV(22), and subunits of the proteasome (23). Although energy-dependent proteases have limited primary sequence identity, they have converged into common >self-compartmentalized= structures which sequester rather non-specific proteolytic active-sites away from other cellular components and prevent the unregulated hydrolysis of proteins in the cell (14,24,25). Numerous active sites line the interior of these cylindrical or chamber-like proteases and are apparently accessed only via narrow portals which are about the width of an alpha-helix, suggesting that substrate proteins must be unfolded prior to hydrolysis.

It is the initial steps of protein degradation which are probably energy-dependent including: tagging the substrate for proper identification by the protease and rendering the substrate accessible to the compartmentalized proteolytic active sites by enzyme complexes which may have reverse chaperone or unfoldase activities (26-28). Thus, the energy-dependent steps of proteolysis are believed to be advantageous checkpoints in the cell to ensure that the proper proteins are committed to unfolding and irreversible destruction.

In this review, we will first describe the biochemical and biophysical properties of 20S proteasomes

which are the self-compartmentalized catalytic cores of larger energy-dependent proteolytic complexes. The catalytic mechanism of peptide bond hydrolysis, subunit composition, distribution among organisms, and assembly of 20S proteasomes will be discussed. Then advances in our understanding of the ATPases (reverse chaperones) required for the energy-dependent degradation of proteins will be presented. We will also outline how energy-dependent proteases such as the proteasome are able to recognize signals which target proteins for degradation. Genomics and bioinformatics will then be used to provide insight into the possible organization of proteasome operons as well as additional energy-dependent proteases such as Lon which may be synthesized in the archaeal cell. Finally, we will discuss the biological role(s) of the archaeal proteasome including its possible involvement in stress responses based on genome information, preliminary physiological studies, and known functions of the analogous eucaryotic enzyme.

### 3. PROTEASOMES AND THE 20S PROTEOLYTIC CORE

Proteasomes are large multicatalytic proteases found in eucarya, archaea, and Gram positive actinomycetes (13,29). In eucaryotic cells, proteasomes are found in the cytosol, nucleus, and associated with the endoplasmic reticulum and cytoskeleton (30-32). Although the cellular location of proteasomes in procaryotes has not been established, biochemical properties of purified complexes suggest that they may be cytosolic and/or loosely associated with the cell membrane (33-39). Proteasomes consist of a 20S catalytic core which degrades unfolded polypeptides and short peptides in the absence of ATP. *In vitro*, most native or aggregated proteins are resistant to proteolytic degradation by 20S proteasomes (40). Thus, it is not clear whether free forms of 20S proteasomes function in degrading proteins in the cell. Eucaryal 20S proteasomes exist as free particles *in vivo* (41) but are also part of larger complexes such as the energy-dependent 26S proteasome involved in ubiquitin-mediated protein degradation as well as the PA28 immunoproteasome which is synthesized in response to IFN-gamma (24,42). In addition, nucleotidase or ATPase complexes such as the recently described PAN (proteasome activating nucleotidase) (43,44) and ARC (AAA ATPase forming ring-shaped complex) (45) are predicted to associate with 20S proteasomes to function in protein degradation in archaeal and eubacterial cells, respectively.

#### 3.1. Architecture of the 20S proteasome

20S proteasomes are cylindrical with a length of 15 nm and a diameter of 11 to 12 nm and are organized as four stacked rings with a central channel as seen in figure 1. This overall architecture is highly conserved from bacteria to man (35). 20S proteasomes are composed of 28 subunits which are related in primary sequence and classify into 14 families which fall into two related superfamilies of alpha- and beta-type (46,47). Immuno-electron microscopy, average projection image analysis, and secondary structure prediction (48,49) reveal that 20S proteasomes have a seven-fold symmetry with alpha-type subunits occupying



**Figure 1.** Transmission electron micrograph of 20S proteasomes from the archaeon *Haloferax volcanii*. Typical four-stacked rings are visible in the side-on views. The central channel is visible in the end-on views. The particles, negatively stained with uranyl acetate, have a length of 15 nm and diameter of 12 nm. Bar, 100 nm.

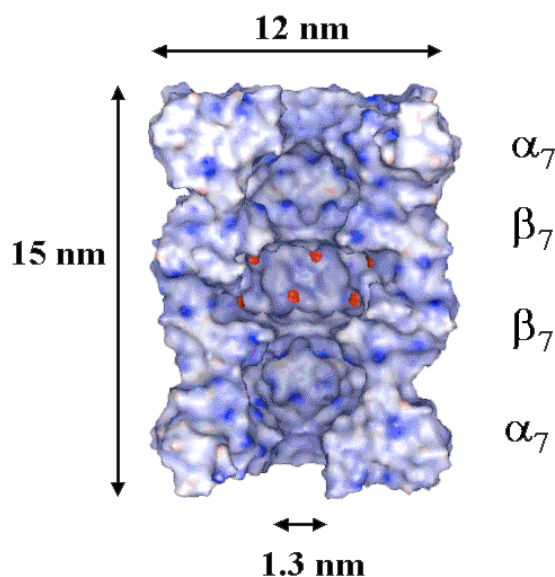

**Figure 2.** Predicted structure of the *Methanosarcina thermophila* 20S proteasome. The image is an atomic model based on the crystal structure coordinates of the 20S proteasomes from *Thermoplasma acidophilum* and yeast. The active sites involved in peptide bond hydrolysis are indicated in red. Computational results were obtained using software programs from Molecular Simulations Inc. (<http://www.msi.com>), and from the Swiss Institute of Bioinformatics (<http://www.expasy.ch>).

the two outer rings and beta-type subunits forming the two inner rings, with each ring composed of seven subunits. The number of *different* subunits which form the 20S proteasome complex varies. The archaeal and eubacterial 20S proteasomes have a fairly simple composition of two to four different subunits with the majority of these organisms having single alpha- and beta-type subunits. Eucaryal 20S proteasomes are composed of 14 different subunits which are divided equally into seven-alpha and seven beta-type. Each eucaryal subunit is located at a defined position in the heptameric rings to generate a complex with overall two-fold symmetry (50-53).

The X-ray crystal structures of the 20S proteasomes of the archaeon *Thermoplasma acidophilum*

and eucaryote *Saccharomyces cerevisiae* were determined to 3.4 and 2.4 Å resolution, respectively (54,55). This detailed structural information confirms the overall architecture of the 20S proteasome, provides insight into the mechanism of protein degradation, and enables atomic models of related 20S proteasomes to be developed (figure 2). Ironically, the archaeal 20S proteasome is similar in overall structure to molecular chaperones such as GroEL which promote protein folding (56,57). Both complexes are cylindrical with sevenfold rotational symmetry around a large central cavity that is only accessible by an entry port at each end of the particle. There are fundamental differences, however, between these two complexes. The channel openings at each end of the GroEL cylinder are 4.5 nm in diameter. This is just wide enough to trap nonnative polypeptides while protecting the hydrophobic patches which form these binding sites from self-associating with other GroEL molecules (58-60). In contrast, the *T. acidophilum* 20S proteasome has much narrower openings of only 1.3 nm formed by the alpha subunits which appear to protect most proteins from entering the cylindrical channel which harbors the proteolytic active sites (54). Additional enzymes or cofactors are apparently needed to unfold protein substrates for access to this channel. This is supported by studies which demonstrate that polypeptides unfolded by heat (43,61,62), oxidative damage (63-67), or disulfide bond reduction (40,68-70) are usually degraded by purified 20S proteasomes; whereas, most native proteins are resistant to hydrolysis (40,63,68). Furthermore, covalent attachment of Nanogold particles of 2 nm diameter to unfolded insulin prevents its degradation by 20S proteasomes (40). Electron micrographs suggest that this bulky label blocks the substrate protein from entering the two orifices at each end of the 20S proteasome (40). These narrow substrate openings may also ensure a processive mechanism of degradation by restricting the size of products released from the complex to short polypeptides (3 to 30 amino-acid chains) which have limited secondary structure (12,71).

The yeast 20S proteasome is similar in overall architecture to the *T. acidophilum* enzyme but forms a larger number of intersubunit contacts which may be necessary for subunit assembly (55). The N-termini of the alpha subunits are disordered in the archaeal 20S proteasome structure but, in contrast, appear to form tightly closed constrictions or >gates= blocking the entry ports at the ends of the yeast 20S proteasome (55). Thus, additional regulatory components are likely required to associate with the yeast 20S proteasome and promote an open gate conformation for protein substrates to enter the central proteolytic channel (24). Consistent with this mechanism, 19S cap (PA700) and 11S (PA28) regulatory complexes interact with the ends of a variety of eucaryal 20S proteasomes and stimulate peptide bond hydrolysis (24). The biochemical properties of eucaryal 20S proteasomes also support this model, since when purified in the presence of glycerol, many are in a latent state and require heat, chaotropic agents, or hydrostatic pressure for activation (72-75). Thus, regulatory complexes may control gates at each end of the 20S proteasome and regulate substrate entry. The side windows of 1.3 nm originally noted in the

## Proteasomes in the Archaea

structure (55) may be used for the rapid discharging of degradation products (24).

The yeast and *T. acidophilum* 20S proteasomes contain three inner cavities which include two antechambers and a central chamber (76). The antechambers are each formed by one alpha-ring and one beta-ring and have a volume of 59 nm<sup>3</sup> with 2.2 nm openings to the central chamber of 84 nm<sup>3</sup> formed by the two beta-rings (54,55). It is the central chamber which harbors the 6 to 14 active sites responsible for catalyzing the hydrolysis of peptide bonds (54,55). *In vitro*, 20S proteasomes are able to hydrolyze unfolded proteins in the absence of ATP. However, it is unclear how these unfolded polypeptides are translocated by an energy-independent mechanism from the alpha-ring openings to the active sites of the beta subunits which are 8 to 10 nm away. Why 20S proteasomes have antechambers also remains to be determined. Clusters of hydrophobic residues which line the antechamber may preserve the substrate protein in an unfolded state and direct the polypeptide chain toward the active site clefts of the central chamber (24). The antechambers may also play a role in restricting access to the central chamber of the 20S proteasome (77). Interestingly, other self-compartmentalized proteases such as ClpP and the related HslV do not have antechambers and are still functional in the cell (78,79).

### 3.2. Catalytic mechanism of peptide bond hydrolysis

Small synthetic peptide substrates are often used to characterize the peptidase activities of purified 20S proteasomes. Eucaryal 20S proteasomes have three major peptidase activities including hydrolysis of peptide bonds carboxyl to hydrophobic, basic, and acidic amino-acid residues (chymotrypsin-like, trypsin-like, and postglutamyl peptide hydrolyzing (PGPH) or caspase-like activities, respectively) (80-82). Mutagenesis (83-85) and co-crystallization of the yeast 20S proteasome with specific inhibitors (55) suggest that beta1, beta2, and beta5 subunits (86) are responsible for the caspase-, trypsin- and chymotrypsin-like activities, respectively. 20S proteasomes isolated from higher eucaryotes, including mammals and lobster, have two additional peptidase activities including cleavage between small neutral amino acids and after branched chain residues (SNAAP and BrAAP activities) (80,87). Mammalian 20S proteasomes also undergo a significant change in subunit composition after IFN-gamma induction which results in replacement of the constitutive >active= beta subunits with the three beta subunit homologs, beta1i (LMP2), beta2i (LMP10/MECL-1), and beta5i (LMP7) which are also catalytically active (88-92). This alters the cleavage specificity of the 20S proteasome during the hydrolysis of peptides and proteins (93-98) and may facilitate the generation of antigenic peptides (99-102). Peptidase activities of 20S proteasomes are further enhanced and modified by association with the IFN-gamma-inducible PA28 (11S) regulatory complex (87,103,104).

Procaryotic 20S proteasomes are relatively simple in the types of peptides hydrolyzed compared to

those of eucaryotes. The majority have only chymotrypsin-like peptidase activity including those of the eubacteria *Rhodococcus erythropolis* (37), *Streptomyces coelicolor* (38), *Frankia* strain ACN14a/ts-r (39) as well as the archaea *T. acidophilum* (62,105) and *Haloferax volcanii* (34). 20S proteasomes of the methanoarchaea *Methanosarcina thermophila* (61) and *Methanococcus jannaschii* (43) are somewhat unusual with high levels of both chymotrypsin- and caspase-like peptidase activities. Only low levels of trypsin-like peptidase activity have been observed for archaeal proteasomes (12,43,61). Some of these enzymes are stimulated by SDS (12,61) but do not appear to purify in a latent state suggesting that the openings of the alpha-rings do not significantly restrict access of peptides and unfolded proteins to the beta subunit active sites. Analysis of the peptide products generated during the degradation of proteins by *T. acidophilum* and eucaryotic 20S proteasomes reveal different cleavage patterns which do not appear to correlate with preferences of peptide substrates (68,106-109). Thus, peptidase activities provide useful insight into how small peptides bind to the active sites formed by the beta-type subunits but may not necessarily indicate what types of products are generated from protein substrates.

Several beta-type subunits of 20S proteasomes belong to the N-terminal (Ntn) hydrolase family (110) which includes HslV (79), penicillin acylase (111), glutamine-phosphoribosyl-pyrophosphate amidotransferase (112), and lysosomal aspartyl glucosaminidase (113). The common feature of this family is the generation of an N-terminal amino acid which is used as an active-site nucleophile in hydrolysis and is often mediated by autocatalytic removal of a propeptide (61,114). Among the beta-type proteasomal subunits which undergo such maturation, an N-terminal Thr is exposed to reveal a gamma-oxygen which acts as the nucleophile and an alpha-amino group which is the likely proton acceptor in the hydrolysis of peptide bonds. In addition, a salt bridge formed by conserved Lys33 and Asp/Glu17 residues of mature beta subunits may also be involved in accepting the Thr1 side-chain proton through a charge-relay system.

This proposed mechanism of peptide bond hydrolysis was elucidated by mutagenesis, inhibitor, and crystallography studies of 20S proteasomes (54,55,61,115,116). Initially, all Ser, Cys, and His residues of the *T. acidophilum* 20S proteasome were systematically modified to Ala with no change in protease activity (117). This revealed that the 20S proteasome was not an unusual type of serine protease as previously suggested by inhibitor studies (62,80,118,119). Further evidence for the mechanism of proteolysis came from two simultaneous studies on the *T. acidophilum* 20S proteasome. The N-terminal Thr of the beta-subunit was modified to an Ala which resulted in abolishment of the chymotrypsin-like peptidase activity (116); and the 20S proteasome was co-crystallized with a peptide aldehyde, acetyl-Leu-Leu-norleucinal, which bound to the active site and inhibited peptidase activity (54). The results of these studies were in agreement with the finding that a hydrolyzed form of the antibiotic lactacystin, *clasto*-lactacystin beta-lactone,

## Proteasomes in the Archaea

covalently bound to the N-terminal Thr residues of a subset of beta-type subunits to inhibit several peptidase activities of a mammalian 20S proteasome (115,120). Amino acid sequence alignment of beta-type subunits predicts that only three of the seven constitutive eucaryal beta-type subunits are >active= and harbor the residues involved in peptide bond hydrolysis (116). This is confirmed by co-crystallization of the yeast 20S proteasome with peptidase inhibitors demonstrating that caspase-, trypsin-, and chymotrypsin-like activities are likely mediated by the beta1, beta2, and beta5 subunits, respectively (55). These results are also consistent with the previous *in vivo* mutagenesis studies which suggest that pairs of active and >inactive= beta-type subunits cooperate together to catalyze the three different peptidase activities (84,85,121-124). In contrast, the methanoarchaeal 20S proteasomes have 14 identical beta subunits which catalyze both chymotrypsin- and caspase-like peptide activities (61).

Whether the amino group of Thr1 or Lys33 is the primary proton acceptor of 20S proteasomes in the hydrolysis of peptide bonds remains to be directly determined. Lys33 is probably protonated at physiological pH (54) and is not needed for the trypsin-like peptidase activity of the *Methanosarcina* 20S proteasome (61). In addition, yeast mutagenesis studies reveal that N-alpha-acetylation of propeptide deleted beta subunits inhibits peptidase activity and suggests that the Thr1 alpha-amino group is involved in the catalytic mechanism of the proteasome (125). Water molecules may also play a role in proteolysis as a proton shuttle between the N-terminal Thr gamma-oxygen and alpha-amino group based on their location in the yeast 20S proteasome crystal structure (77).

Proteasomes hydrolyze unfolded polypeptides by an apparent processive mechanism in the cell, *i.e.*, they completely degrade a substrate protein to oligopeptides before attacking another protein molecule (11,12,126). This mechanism is probably an intrinsic feature of 20S proteasomes and may be accounted for by a trapping of substrate inside the cylinder. When examined *in vitro*, 20S proteasomes alone processively hydrolyze relatively small, unfolded substrate proteins in the absence of ATP or cofactors. This has been demonstrated using a fluorescent derivative of bovine beta-casein, a 209-amino acid globular protein containing 5 to 6 residues of fluorescein isothiocyanate (FITC) per molecule, as a substrate protein (11,12). The *T. acidophilum* 20S proteasome as well as rabbit muscle 26S and 20S proteasomes were incubated with a molar excess of FITC-labeled-casein and the fluorescent peptide products of the reaction were analyzed by reversed-phase HPLC. These enzymes each generated a specific pattern of products which was independent of time and suggested a processive mechanism of degradation. Although association of the eucaryal 20S proteasome with the 19S cap in the presence of ATP modified the pattern of peptides generated, it did not influence processive hydrolysis of FITC-labeled-casein (11). The kinetics of hydrolysis of the 30-amino acid insulin B-chain by 20S proteasomes isolated from human-red blood cells support this model (127). The related Lon and ClpAP proteases of *E. coli* also degrade proteins processively but, unlike the

20S proteasome, the mechanism appears to be linked to ATP hydrolysis (3,10,128,129). Interestingly, some proteins are not degraded in a processive mechanism by the 20S proteasome and instead are cleaved into large fragments. This occurs *in vivo* during the cotranslational processing of NF-kappaB p105 and related NF-kappaB p100 to the smaller p50 and p52 proteins (130,131). Furthermore, the degradation of unfolded S-carboxamidomethylated lysozyme of 129 amino acids by bovine 20S proteasomes is nonprocessive *in vitro* with the release of intermediate fragments of masses greater than 7000 Da (about 60 amino acids) which are later hydrolyzed to smaller peptides of 6 to 20 amino acids (132). Thus, processive hydrolysis of some protein substrates may be more efficient when 20S proteasomes are associated with energy-requiring complexes such as the eucaryal 19S cap or archaeal PAN protein. It is likely that the majority of substrate proteins are hydrolyzed processively in the cell to avoid the accumulation of partially digested proteins and peptide fragments which would otherwise be harmful.

The exact determinant of size and type of peptide products generated by 20S proteasomes is unclear. Originally it was noted that the average length of products synthesized during hydrolysis of proteins by the *T. acidophilum* 20S proteasome was between 7 to 9 amino acids (106) which was in good agreement with the distance between the proteolytic active sites of 2.8 nm (54). Thus, the spacing between the multiple active sites was proposed to act as a molecular ruler in determining the length of peptide product (54,55,106,133,134). However, when 20S proteasomes are incubated with molar excess of substrate protein and the relative amounts of peptide products are determined at a constant rate of degradation, the individual products range from 3 to 30 amino acids and their sizes fit a log-normal distribution (11,71). Thus, it is possible that high concentration of active sites in the central proteolytic chamber and/or size of the alpha-ring pore may play a role in determining the types of products released from 20S proteasomes (11). 20S proteasomes may also be oligocarboxypeptidases which determine product size by using a mechanism in which long-lived acyl-enzyme intermediates are anchored at one active site and then cleaved at an adjacent one (77). Based on studies which demonstrate allosteric control of the peptidase sites of rabbit muscle 20S proteasomes (135), there may also be an ordered, cyclical >bite-chew= mechanism of protein degradation which determines the type of products generated. In this mechanism, the chymotrypsin-like site would be involved in the initial cleavage or >bite= of proteins followed by a stimulation of caspase-like activity which facilitates the >chewing= of polypeptide fragments in the central chamber (135).

### 3.3. Distribution and subunit composition of 20S proteasomes

Genuine eubacterial 20S proteasomes have only been identified in the high-G+C Gram-positive actinomycetes which may have acquired proteasomal gene(s) by horizontal transfer (13,29). The majority of eubacteria, instead, produce the HslV protease which is a self-compartmentalized Ntn-threonine hydrolase and a

## Proteasomes in the Archaea

divergent member of the beta-type proteasome subfamily (29,136,137). HslV is a cylindrical homooligomer of two-stacked hexameric rings with putative substrate openings of about 0.7 nm at each end of the cylinder axis (79). Proteasomal alpha-type proteins have not been identified in these eubacteria including organisms whose genomes have been completely sequenced (13). Instead, the six to seven membered-ring HslU ATPase interacts directly with HslV and is required for the hydrolysis of peptide and protein substrates in an ATP-dependent reaction (136). Interestingly, the occurrence of HslUV and 20S proteasomes among all organisms appears to be mutually exclusive, and some organisms such as the cyanobacterium *Synechocystis* sp. PCC6803 as well as the eubacterial pathogens *Mycoplasma genitalium*, *Mycoplasma pneumoniae*, *Chlamydia trachomatis*, and *Treponema pallidum* do not contain either protease (13).

The number of different subunits which form genuine 20S proteasomes varies, but all subunits are related and classify into either alpha- or beta-type superfamilies. This is based on their relationship to the single alpha and beta subunits which form the *T. acidophilum* 20S proteasome complex, the first to be completely sequenced (47,138). This simple two subunit composition appears to be widespread among 20S proteasomes from other archaea including *Methanosarcina*, *Methanococcus*, *Methanobacterium*, and *Archaeoglobus* species as well as the actinomycetes *Mycobacterium*, *Frankia*, *Streptomyces*, and most *Rhodococcus* species (13). *Rhodococcus erythropolis* strain N186/21 is an exception among the eubacteria in that it produces two alpha-type and two beta-type subunits which form a single 20S proteasome (37,139). However, several archaea including *Haloferax*, *Pyrococcus*, and *Aeropyrum* species apparently synthesize three different 20S proteasome subunits (34,140-142). Recent analysis of proteasomes isolated from *H. volcanii* reveals that a single beta-type and two different alpha-type subunits are synthesized in this organism (34). This study combined with homologous production of epitope (poly-histidine)-tagged derivatives of the individual subunits reveals that at least two different 20S proteasome complexes of 1) alpha1, alpha2, and beta and 2) alpha1 and beta subunits are synthesized in *H. volcanii* (S. J. Kaczowka and J. A. Maupin-Furlow, unpublished). Based on genome sequence, *Pyrococcus* species such as *P. abyssi*, *P. horikoshii* and *P. furiosus* encode a single alpha-type and two beta-type proteins (141,142) (<http://www.ncbi.nlm.nih.gov/BLAST/unfinishedgenome.html>). The two beta proteins of *Pyrococcus* are predicted to be processed at the N-terminus to generate active subunits with highly conserved Thr1, Asp/Glu17, and Lys33 residues. Previously, 20S proteasomes isolated from *P. furiosus* were shown to be composed of single alpha and beta subunits based on SDS-PAGE and protein sequence analysis (36). Whether or not the second beta subunit (beta2) is synthesized and incorporated into a 20S proteasome with all three subunits and/or a separate alpha-beta2-20S proteasome in *Pyrococcus* remains to be determined. Based on genome sequence analysis, *Aeropyrum* also appears to produce three different 20S proteasome proteins including a single alpha-type and two

beta-type proteins (140). Only one of the two beta proteins from *Aeropyrum* (beta1) is predicted to be processed and to generate an >active= beta subunit. Why some archaea appear to synthesize multiple 20S proteasomes of different subunit composition remains to be determined.

The eucaryal 20S proteasomes are highly complex with seven different alpha-type and seven different beta-type proteins assembling into an ordered complex of two-fold symmetry (50-53). The complete genome sequence of *S. cerevisiae* (143) as well as biochemical studies suggest that lower eucaryotes produce a single 20S proteasome of 14 different subunits (144,145). Higher eucaryotes such as mammals and zebrafish, however, appear to produce multiple 20S proteasomes of different subunit composition including a general housekeeping proteasome which is constitutively produced in most cell lines and an immuno-proteasome which is produced at high levels in cells involved in the immune system as well as other cell types after IFN-gamma induction (146,147). Differences between these two 20S proteasomes include replacement of the constitutive >active= beta1, beta2, and beta5 subunits by the >active= IFN-gamma inducible beta1i, beta2i, and beta5i to generate a proteasome with altered peptidase and protease activities (93,94,148,149). In addition, two distinct forms of beta1i have been found in isolated 20S proteasomes with one corresponding to the >inactive= primary LMP2 translation product and the other to the N-terminally processed >active= form (150).

### 3.4. Assembly of 20S proteasomes

The pathway of 20S proteasome assembly and the function(s) of the beta propeptides are not fully established and appear to differ somewhat among the three domains (151). One major difference is the number of beta-type subunits which are cleaved at the N-terminus during maturation of the proteolytic complex. All of the beta-type subunits of 20S proteasomes which have been characterized from procaryotes are processed to expose an active site Thr1 residue. An exception may be the crenarchaeon *Aeropyrum* which appears to encode both active and inactive beta-type subunits based on the genome sequence (140). In contrast, the yeast 20S proteasome contains two unprocessed subunits, beta3 and beta4, and five processed subunits, including the >inactive= beta6 and beta7 as well as the >active= beta1, beta2, and beta5 subunits (152). An additional difference is the length and sequence of the beta propeptide. Some beta-type proteins do not even have propeptides as seen for many eubacterial HslV proteases; whereas, others have rather large propeptides *i.e.* the 75 residue propeptide of the yeast beta5 protein (figure 3). Interestingly, higher eucaryotes use alternative leader exons to influence the length of some propeptides including those of the beta1i and beta5i proteins (150,153).

Proteolytic exposure of the N-terminal amino-group of beta-type subunits is autocatalytic in eubacterial (154), archaeal (61,114), yeast (155,156), and mammalian (157) proteasomes and most commonly occurs at a conserved Gly-Thr bond (figure 3). Exceptions include the

## **Proteasomes in the Archaea**

processing of beta6 and beta7 proteins of yeast at His-Gln

## Proteasomes in the Archaea

<b>Archaeal 20S proteasome beta subunits</b>			
Mth beta	MNDKNTLKG	TTIVG	9
Af beta	MSMIEEKIYKG	TTIVG	11
Mst beta	MDNDKYLKG	TTIVG	9
Ta beta	MNDILETG	TTIVG	8
Mj beta	MDVMKG	TTIVG	6
Pab beta1	MLQLTEFKG	TTIVG	10
Pab beta2	MNRKIG	TTIVG	6
Hfv beta	MRTPIHDEFSGRLLDSLNGDRSNVFGPELGEFSNADRRADELGDKEIKTG	TTIVG	49
Ss beta	MNPKLTVIFLLLLM/IMGNELOLENKILKG	TTIVG	31
Ape beta1	MGAGCKVAEWIAGGLEGPAGRGLDERMVRSG	TTIVG	31
Ape beta2	MDSVIHGWAQVIQIRPGRSQEYIGPASDLYASGCCCLSFAGATALG	?	
<b>Eubacterial 20S proteasome beta subunits</b>			
Fr beta	MADEMGGAGRLPAVFMIPGTSSFDLFSOSAPHLPLGARGGLPGPVTEVAHG	TTIVA	52
Stc beta	MEANIRSTGRLLPAAFLTPGSSSFMDFLGEHOPEMLPGNROLPPVQGVIEAPHG	TTIVA	53
Mbl beta	MTRSEFDRLFINLAFPGISVINOSFVDLLRROAPELPPVSLGGGSGGGGOLSHG	TTIVV	56
Mbs beta	MIWRDNOSFPQPTLNIITGIPSVVPLDSSFSSELLSROAPELPPVNRVAYG	TTIVG	49
Mbt beta	MIWELPDRLSINLSSTPAVDLSSFDLFRROAPELPPASISGGAPLAGGDAOLPHG	TTIVA	57
Re beta2	MTVDRAPRITDGTDLRSFGSNLSSFSYELRVHAPPELLPQNRFAITGGVVMGGGVAPHG	TTIVA	59
Re beta1	MTADRPALRTGDRDTRLRSFGSNLSSFDYLRGHAPELLPENRIGHRSFSTRGGDMESGDLAPHG	TTIVA	65
<b>Eubacterial HslV family</b>			
Cj HslV	MFHA	TTILA	4
Bs HslV	MSSFHA	TTIFA	6
Tm HslV	MKFKG	TTILV	5
Aa HslV	MEVKA	TTILA	5
Rp HslV	MSDNFALHG	TTILC	9
Bb HslV	MSFKG	TTIVA	5
Hp HslV	MFEA	TTILG	4
Ph LapC	M	TTIVC	1
Ec HslV	M	TTIVS	1
Hi HslV	M	TTIVS	1
Ll HtpI	M	TTIIC	1
<b>Yeast 20S proteasome beta subunits</b>			
Sc beta5	MQAIAIDSFSPVNRLLKELQYINEQNLESDFVIGASQFORLAPSLIVPPIASPOOFLRAHIDDSRNPDKIKAHG	TTILA	75
Sc beta2	MAGLSFDNYQRFNFLAENSHIOPKATSTG	TTIVG	29
Sc beta1	MNGIQVDINRLKKEVSLG	TSIMA	19
Sc beta3	M SDPSSINGGIVVA		1
Sc beta4	MDILLG		0
Sc beta6	MATIASEYSSEASNIPIEH QFNFPYGDNGTILG		19
Sc beta7	MNHDPFSWGRPADSTYGAYNQITANAGASPMVN TQQPIVTIGISVIS		33

**Figure 3.** Propeptides of beta-type subunits of 20S proteasomes and HslV proteases. Highlighted residues include Met residues removed by methionine aminopeptidases in addition to residues removed after cleavage of beta-propeptides as determined by N-terminal amino acid protein and/or DNA sequence analysis. Number of residues removed indicated on right. Abbreviations for archaeal beta subunits: Mth, *Methanobacterium thermoautotrophicum* Delta H; Af, *Archaeoglobus fulgidus*; Mst, *Methanosarcina thermophila* TM-1; Ta, *Thermoplasma acidophilum*; Mj, *Methanococcus jannaschii*; Pab, *Pyrococcus abyssi*; Hfv, *Haloferax volcanii*; Ss, *Sulfolobus solfataricus* P2; Ape, *Aeropyrum pernix* K1. Abbreviations for eubacterial beta subunits: Fr, *Frankia* strain ACN14a/+s-R; Stc, *Streptomyces coelicolor*; Mbl, *Mycobacterium leprae*; Mbs, *Mycobacterium smegmatis*; Mbt, *Mycobacterium tuberculosis*; Re, *Rhodococcus erythropolis* NI86/21. Abbreviations for eubacterial HslV family: Cj, *Campylobacter jejuni*; Bs, *Bacillus subtilis*; Tm, *Thermotoga maritima*; Aa, *Aquifex aeolicus*; Rp, *Rickettsia prowazekii*; Bb, *Borrelia burgdorferi*; Hp, *Helicobacter pylori*; Ph, *Pasteurella haemolytica*; Ec, *Escherichia coli*; Hi, *Haemophilus influenzae*; Ll, *Lactobacillus leichmanni*. Abbreviation for yeast beta-type subunits: Sc, *Saccharomyces cerevisiae*.

and Asn-Thr bonds, respectively (152) (figure 3). The common fold of the Ntn hydrolase family (110) suggests that beta-type proteins are processed by an intramolecular mechanism due to the conformational strain at the cleavage site created by an unusual beta-sheet structure. Yeast mutagenesis studies suggest that maturation of beta proteins to active subunits occurs by an intrasubunit autolytic event independent of the presence of other active beta subunits (158). Before removal of the beta propeptide, the active site N-terminal Thr amino group of the mature protein is not yet exposed in the precursor to accept protons for peptide bond hydrolysis. A catalytic water molecule may instead abstract a proton from the hydroxyl group of the Thr residue of the precursor (77) consistent with crystal structures of Ntn hydrolases (55,111). This would

promote nucleophilic attack by the Thr gamma-oxygen on the carbonyl carbon of the preceding Gly-Thr bond of the beta precursor which is ultimately hydrolyzed to release the propeptide and expose the active site Thr as the N-terminal residue of the mature protein. In contrast, the inactive beta6 and beta7 subunits which are intermediately processed are likely cleaved by an intermolecular mechanism mediated by the active beta subunits (159-161). An *in vitro* study of the *T. acidophilum* 20S proteasome suggests that archaeal beta proteins may also mature by an intermolecular event (114). Mixing wild-type beta proteins with beta mutants, which alone are not processed, results in processing of up to 90% of the mutant beta protein in 20S proteasomes heterologously synthesized in *E. coli* (114). Interestingly, the conserved Gly residue amino to the



## Proteasomes in the Archaea

cleavage site of the propeptide appears to be more important for propeptide removal than the Thr residue carboxyl to this site (114).

The exact role(s) of the propeptide at the N-terminus of the beta-type precursor proteins of 20S proteasomes is not fully understood. Although no direct evidence is available, the beta propeptide is widely believed to protect the cell from unregulated hydrolysis of intracellular proteins which would otherwise occur if 20S proteasome assembly intermediates were exposed in the cytosol. The beta propeptide appears to be needed for proper folding of the beta precursor by acting as a molecular chaperone to protect the beta protein against degradation or premature multimerization similar to the propeptides of elastase, alpha-toxin, and lipase (162). The yeast beta propeptides also protect the active site N-terminal Thr from modification prior to incorporation into 20S proteasomes as described below.

Many proteasome-like HslV proteases do not even have a propeptide and instead rely upon a methionine aminopeptidase to expose an active site Thr1 residue (figure 3). However, unlike genuine 20S proteasomes, HslV displays only weak peptidase activity and binding of inhibitors in the absence of the ATPase regulatory component, HslU (136,163,164). HslU and ATP are apparently needed to allosterically modify the geometry of the HslV active site to increase the affinity of binding to peptides and proteins (165). Thus, in the absence of the regulatory HslU ATPase, assembly intermediates of HslV probably have limited activity in the non-specific, unregulated hydrolysis of proteins in the cell.

The relatively large eubacterial beta propeptides, which range from 49 to 65 residues (figure 3), are needed *in cis* or *trans* for productive assembly of 20S proteasomes *in vitro* as well as in recombinant *E. coli* (154). Likewise, the yeast beta5 propeptide of 75 amino-acid residues is essential for incorporation of the beta5 subunit into active 20S proteasomes and can be supplied *in trans* (155,166). Thus, many beta propeptides appear to facilitate folding of the precursor or are necessary for appropriate contacts with other subunits or proteins for efficient 20S proteasome assembly. Removal of the propeptide from the yeast beta1, beta2, and beta5 residues by mutagenesis prior to 20S proteasome assembly suggests that another critical function of the beta propeptide is protection of the N-terminal catalytic Thr residues against N-alpha-acetylation (125). Surprisingly, many archaeal beta propeptides are relatively short ranging from 6 to 11 residues (Fig. 3) and are dispensable in the assembly of 20S proteasomes *in vitro* as well as in recombinant *E. coli* (43,61,114,167). Even the 49-residue beta propeptide of *H. volcanii* is not essential for *in vitro* assembly of 20S proteasomes from individual alpha1 and beta subunits dissociated in low salt (34). Thus, the archaeal beta propeptide appears to have minimal if any role in the actual assembly mechanism of individual subunits into active 20S proteasomes outside the archaeal cell. Instead, the archaeal beta propeptide may be needed for proper folding, stabilization, and/or protection of the N-terminus of the beta subunit when synthesized *in vivo* as

suggested by a recent study in *H. volcanii* (S. J. Kaczowka and J. A. Maupin-Furlow, unpublished).

The order and mechanism of incorporation of individual subunits into active 20S proteasomes is still unclear. In the eubacteria, the alpha- and beta-type proteins alone remain monomeric, but when mixed together form half (alpha<sub>7</sub>beta<sub>7</sub>) and full 20S (alpha<sub>7</sub>beta<sub>7</sub>beta<sub>7</sub>alpha<sub>7</sub>) proteasomes (154). Mature, correctly processed beta subunits are not detected in these half proteasomes suggesting that cleavage of the beta propeptide occurs during the joining of the half proteasomes to form active 20S proteasomes (154). The alpha and beta proteins of the eubacteria must interact to initiate half-complex formation, and the rate-limiting step of assembly appears to be the subsequent processing of the beta propeptide after dimerization of the two half proteasomes (154). Unlike the archaea and eucarya, the genes encoding the alpha and beta proteins of the eubacterial 20S proteasome are in tandem and appear to be co-transcribed from the same operon (29). This may ensure equimolar synthesis of these subunits for 20S proteasome assembly (29).

Like the eubacteria, the archaeal beta proteins alone are inactive even in the absence of propeptides and form only monomers, dimers, trimers, or aggregates (43,61,167). However, in contrast, archaeal alpha subunits spontaneously self-assemble into single and/or double stacked heptameric rings when produced in recombinant *E. coli* (43,61,167). Mutagenesis of archaeal alpha subunits reveals that the N-terminal alpha-helix, which is absent in beta-type proteins, is important for alpha-ring and 20S proteasome complex formation (167). The archaeal alpha-ring appears to provide the scaffolding for assembly of the beta-ring in the formation of active 20S proteasomes (61,167). Whether additional maturation factors are necessary for either eubacterial or archaeal 20S proteasome assembly *in vivo* is unclear.

Assembly of eucaryal 20S proteasomes is more complicated with 14 different subunits located at specific positions in either the alpha- or beta-ring. Some eucaryal alpha subunits including the human alpha7 (HsC8) and *Trypanosoma brucei* alpha5 proteins self-assemble into single, double, and even four-stacked protein rings when produced in recombinant *E. coli* (168,169). The human alpha7 protein also induces heterologous ring formation when synthesized with alpha1 (PROS27) and alpha6 (PROS30) which are adjacent to alpha7 in the final ring of the 20S proteasome (170). Similar to archaea, the N-terminus of eucaryal alpha-type subunits is essential for incorporation of these subunits into 20S proteasomes (171). It remains to be determined whether all seven eucaryal alpha-subunits spontaneously assemble into a distinct ring or whether the alpha subunits require interaction with beta-type proteins or additional factors for proper oligomerization. Eucaryal assembly intermediates of 13S to 16S have been identified *in vivo* which contain at least six alpha-type and several beta-type proteins (41,172-174). Thus, alpha-ring formation may precede beta protein incorporation although further studies are needed (172). Unprocessed and partially processed forms of beta-type

## Proteasomes in the Archaea

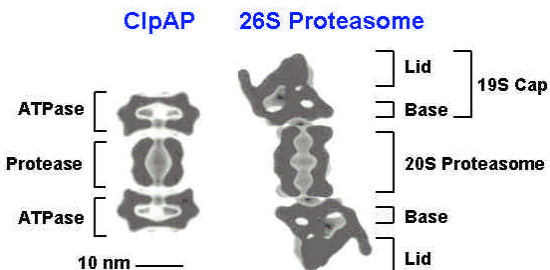

**Figure 4.** Comparison of energy-dependent 26S proteasome to ClpAP protease. The self-compartmentalized proteolytic chambers (20S proteasome and ClpP protease) and energy-dependent AAA<sup>+</sup>-regulatory complexes (19S cap or PA700 regulator and ClpA ATPase) are indicated. The 19S cap Lid and Base domains are also labeled. The Base domain is composed of eight subunits which include six AAA<sup>+</sup> proteins which are proposed to form a hexameric ring similar to ClpA. Figure adapted with permission from S. Wickner, M. R. Maurizi, and S. Gottesman.

proteins have been observed in 13S to 16S half proteasome complexes including the beta1i, beta5i, and beta6 proteins (41,157,172,174). In addition, putative maturation factors are associated with half proteasomes including Ump1 (175,176) and Hsc73, an Hsp70 homolog (173,177). Ump1 appears to influence the conformation of beta propeptides and ensure proper autocatalytic processing of the beta-type subunits (175). Ump1 then becomes trapped inside the assembled, active 20S proteasome for destruction.

### 4. PROTEASOME-ASSOCIATED AAA<sup>+</sup> ATPases

Self-compartmentalized proteases alone typically catalyze only the hydrolysis of unfolded polypeptides and short peptides and are unable to degrade most native or aggregated proteins. Instead, separate ATPase (nucleotidase) domains or complexes are needed to activate energy-dependent hydrolysis of folded and aggregated proteins by these proteases (28). The ATPase component is likely to function as a reverse chaperone to unfold and disaggregate protein substrates and to facilitate their entry into the chamber which harbors the proteolytic active sites.

#### 4.1. AAA<sup>+</sup> superfamily

The majority of ATPases involved in energy-dependent proteolysis classify to the AAA family (ATPases associated with various cellular activities) or AAA<sup>+</sup> superfamily (178-183). The Rpt (regulatory particle triple-A) subunits of the 26S proteasome, archaeal PAN, ARC of the actinomycetes, ClpX, ClpA, HslU, Lon, and FtsH which are all likely involved in proteolysis and are included in this superfamily (180). Molecular chaperones such as the *S. cerevisiae* Hsp104 protein and other enzymes mediating protein:protein interaction are also related. The AAA proteins are P-loop nucleotidases with a characteristic 250 residue domain which includes a Walker A motif (G-X<sub>2</sub>-GXGKT), predicted to be involved in coordination of Mg<sup>2+</sup> and formation of hydrogen bonds with nucleotide triphosphates including the beta- and gamma-phosphates,

as well as a modified Walker B motif or >DEAD= box also predicted to be involved in Mg<sup>2+</sup> binding and ATP hydrolysis (184,185). A second region of homology or SRH motif [(T/S)-(N/S)-X<sub>5</sub>-DXA-X<sub>2</sub>-R-X<sub>2</sub>-RX-(D/E)] which distinguishes AAA<sup>+</sup> proteins from the broader family of Walker-type ATPases is also conserved and is involved in ATP hydrolysis (186). These proteins also contain a C-terminal helical extension or substrate selection and discrimination (SSD) domain which is implicated in substrate protein binding for the ClpX, ClpB, ClpA, HslU, and Lon complexes (187,188). Modification of an N-terminal coiled-coil domain found in many AAA<sup>+</sup> proteins also influences activities including: nucleotide hydrolysis by the Rpt2 subunit of the 26S proteasome and related archaeal PAN protein (43,189), binding of substrate proteins to the yeast Yme1-AAA (FtsH-like) protease (190), subunit interaction of the 26S proteasome (191), and autodegradation of ClpA by the ClpAP protease (192).

Recent advances are providing detailed insight into structural features of AAA<sup>+</sup> proteins. X-ray crystal structures of two members of this family have been determined including the delta' subunit of DNA pol III clamp loader (193) and the hexamerization domain D2 of the NSF vesicle-fusion protein (194,195). Cryo-electron micrograph three-dimensional reconstructions of the 26S proteasome (196), ClpAP (197), and VAT (CDC48) (198) also provide insight into overall AAA<sup>+</sup> protein structure. This has led to the development of models which explain how certain AAA<sup>+</sup> proteins function in mediating protein unfolding for eventual degradation by self-compartmentalized proteases (26,28). The AAA<sup>+</sup> ring, which is often hexameric, appears to have an internal cavity and a central pore forming a passage that is continuous with the central channel of proteases such as the 20S proteasome and ClpP (figure 4). Thus, as substrate protein becomes unfolded it may first pass through the central cavity of the AAA<sup>+</sup> complex and then through a passage formed by a combination of the pore of the AAA<sup>+</sup> ring and the narrow openings located at either end of the protease cylinder. The nucleotide providing the energy for proteolysis is likely to bind at the interface of neighboring subunits of the AAA<sup>+</sup> ring with the beta- and gamma-phosphates of the nucleotide interacting with an arginine finger motif, similar to the Ras-RasGAP complex (199). This may provide a mechanism for transducing structural alterations through ATP binding/hydrolysis to mediate intersubunit cooperativity and communication within the AAA<sup>+</sup> ring for protein unfolding (28,193).

#### 4.2. Rpt (AAA<sup>+</sup>) subunits of eucaryal 26S proteasomes

In the eucaryotic cell, several regulatory factors are known to associate with the 20S proteasome and include the 19S cap (PA700), PA28 activator, 300-kDa inhibitor, PI31 inhibitor, and several heat shock proteins (Hsps) (42,200-203). This diversity reflects the central role of the proteasome in a variety of pathways. Of these, the 19S cap, composed of about 20 different subunits, associates with the 20S core to form the energy-dependent 26S proteasome which is involved in the degradation of folded 'native' proteins often covalently tagged with ubiquitin (42,204). Recently, the 19S cap has been separated into Lid and Base domains (205). The Base is the

## Proteasomes in the Archaea

energy-dependent component responsible for recognizing, unfolding, and feeding model 'native' protein substrates such as casein into the proteolytic chamber of the 20S proteasome (205). The Lid is needed for recognition of ubiquitinated proteins and does not directly interact with the 20S core (205). The Base directly associates with the outer alpha-rings of the 20S core and is composed of eight subunits including six which are members of the AAA<sup>+</sup> superfamily (Rpt1 to Rpt6 proteins) (86). Thus, the six AAA<sup>+</sup> (Rpt) proteins of the 26S proteasome Base domain may form a hexameric ring which interfaces the heptameric alpha-ring of the 20S core with symmetry mismatch similar to ClpAP protease (197). Three-dimensional electron microscopy suggests that there is a flexible linkage or Awagging-type movement@ between the 19S caps and 20S core which may be a consequence of this symmetry mismatch (196).

### 4.3. Archaeal proteasome-activating nucleotidase (PAN)

Homologs of the eucaryal Base domain AAA<sup>+</sup> (Rpt) proteins are predicted from archaeal genome sequences and include the PAN protein. The *M. jannaschii* PAN protein is purified as an ATPase and CTPase which forms irregular ring-shaped complexes with diameter similar to the 20S proteasome (43,44). *In vitro*, PAN associates with the ends of 20S proteasomes much like the 19S cap complexes of eucaryotes (43) and activates the hydrolysis of substrate proteins such as bovine beta-casein in the presence of either ATP or CTP (43,44). The N-terminal 73 amino acids of PAN influence the specificity of nucleotides hydrolyzed and are not necessary for activation of beta-casein degradation (43). Interestingly, 5'-adenylyl beta,gamma-imidophosphate (AMP-PNP) is not hydrolyzed by PAN yet supports PAN-dependent activation of beta-casein degradation as determined by the generation of new alpha-amino groups using fluorescamine (43). However, AMP-PNP does not support the conversion of beta-[<sup>14</sup>C]-casein into acid-soluble products (44). These results suggest that binding of a non-hydrolyzable nucleotide analogue to PAN supports a single or limited number of cleavages by 20S proteasomes of substrate protein into large, acid-precipitable products much like the Lon protease of *E. coli* (129).

### 4.4. Eubacterial AAA ATPase-forming ring-shaped complexes (ARC)

The ARC protein of the actinomycetes is predicted to activate proteolysis by 20S proteasomes similar to the archaeal PAN protein. ARC is a divergent member of the AAA<sup>+</sup> family, which in *R. erythropolis* is encoded by a separate operon but linked to genes encoding the alpha2 and beta2 subunits of the 20S proteasome (29,45). The ARC protein purifies as a complex of single and double-stacked hexameric rings which hydrolyzes nucleotides including ATP, CTP, and ADP (45). ARC does not appear to activate protein degradation or associate with the 20S proteasome *in vitro*. However, the association constant for the two purified protein complexes may be too low to detect specific interactions outside the cell (45).

### 4.5. Chaperone activity of AAA<sup>+</sup> proteins

The same energy-dependent AAA<sup>+</sup> complexes which promote the unfolding of proteins for degradation

may also function as molecular chaperones and promote protein folding in the cell. This dual activity would provide a proofreading step following the initial binding of substrate proteins which enables the cell to distinguish between proteins destined for refolding, disaggregation, or destruction (26). The number of ATPase complexes participating in proteolysis and protein folding in the cell is unclear (28). Often when putative >unfoldases= are separated from the protease component, they catalyze the reverse reaction by promoting protein folding and preventing protein aggregation similar to molecular chaperones (190,206-209). Based on *in vivo* studies, the *E. coli* ClpX ATPase not only acts with the ClpP protease in the specific degradation of proteins such as lambdaD0 (210) but also in the specific disassociation of proteins into active monomers, such as the phage MuA transposase tetramer which is disassembled from the DNA after recombination (211). ClpA, the ATPase component of the ClpAP protease, may also act as a chaperone in the transition of bacteriophage RepA dimers to monomers which are then able to reinitiate P1 phage DNA replication in *E. coli* (206,208,212).

In the eucaryal 26S proteasome, the 19S cap (PA700) which contains six Rpt (AAA<sup>+</sup>) subunits may also participate in maintaining the quality control of proteins by functioning as an unfoldase and a molecular chaperone. The 19S cap (PA700) and eight subunit Base domain of this complex which contains the six Rpt (AAA<sup>+</sup>) proteins inhibits the aggregation of incompletely folded, non-ubiquitinated proteins and promotes the refolding of denatured proteins (*e.g.* citrate synthase) to their native state (28,207,209) similar to molecular chaperones (213). A recent study suggests that the chaperone activity of PA700 may operate *in vivo* by playing a non-proteolytic role in nucleotide excision repair to disassemble or rearrange the repair complex in yeast (214). The exact mechanism of the PA700 refolding and disaggregation activity is unclear. The stoichiometric ratios of enzyme to substrate protein needed for activity, ATP-dependance, and detection of unfolded substrate:enzyme intermediates differs somewhat among current studies (207,209)

## 5. SUBSTRATE TARGETING AND SIGNAL RECOGNITION

Many questions still remain as to how a fully functional protein is suddenly targeted for degradation and how abnormal proteins are specifically recognized for hydrolysis by energy-dependent proteases.

### 5.1. Ubiquitin-dependent

One of the most elegant mechanisms of targeting proteins for degradation in eucaryotes is the covalent attachment of multiple chains of a 76-residue ubiquitin protein to the epsilon-amino group of Lys residues of substrate proteins in an energy-dependent reaction (6,215). This is mediated by ubiquitin-activating enzymes (E1) which form a thioester with ubiquitin in the presence of ATP. Then, through a transthiolation reaction, ubiquitin is transferred to ubiquitin carrier/conjugating enzymes (E2). The E2s are often associated with ubiquitin protein ligases

## Proteasomes in the Archaea

(E3) which are the central players in selecting the substrate protein for ubiquitination. E3s may also facilitate hydrolysis of the target protein through direct interaction of the E3:substrate complex with the 26S proteasome (216). There are many signals which are recognized by the ubiquitin system for degradation by the 26S proteasome including: proline-glutamate/aspartate-serine-threonine (PEST) sequences (217), destabilizing N-terminal residues (218), hydrophobic regions (219), phosphorylation states (220), glycine-rich regions (GRR)(221), the destruction box of mitotic cyclins (222,223), and glycosylation state of proteins (224,225). Deubiquitinating enzymes as well as ubiquitin-like proteins such as RUB1 are emerging as further controls which regulate the tagging of proteins for degradation by the proteasome (226-228).

### 5.2. Ubiquitin-independent

There are examples, although limited, of the ubiquitin-independent degradation of substrate proteins by the eucaryal proteasome (229). The prototype is the turnover of ornithine decarboxylase (ODC) which catalyzes the rate-limiting step in polyamine biosynthesis, a pathway directly linked to cell proliferation (230). The non-covalent interaction of ODC with the protein factor antizyme triggers ODC degradation by the proteasome (231-233). Some proteasome substrates, such as IkappaBalpha and c-Jun, are subject to bimodal targeting in which the signal-induced turnover is mediated by ubiquitin and basal turnover is ubiquitin-independent (234-236). Also several non-ubiquitinated proteins bind directly to proteasome subunits including the viral Tax protein which binds to two 20S core subunits (237), the HBx protein of hepatitis B virus which interacts with a proteasomal alpha-type subunit (238), the p55 tumor necrosis factor receptor which binds to a non-ATPase 19S cap protein (239), and an ankyrin repeat protein which binds to an Rpt (AAA<sup>+</sup>) 19S cap protein (240). In addition, the binding of scavenger proteins (e.g., ankyrin-repeat proteins) to substrate proteins appears to signal proteasome-mediated degradation independent of the ubiquitin pathway (240). Some Rpt subunits of the proteasome also form alternative complexes which do not contain the ubiquitin recognition proteins of the 19S cap and appear to recognize and modulate the folding state of protein substrates in the absence of ubiquitin (241). Whether the above examples of ubiquitin-independent interaction with proteasome proteins are exceptions to the ubiquitin-paradigm for proteasome-mediated hydrolysis or commonly used in the cell is unclear.

To date, ubiquitin targeting systems have not been identified in procaryotes including those whose genomes have been sequenced (<http://www.ncbi.nlm.nih.gov/Entrez/Genome/org.html>). Furthermore, nothing is known about how substrate proteins are recognized for degradation by proteasomes in the archaea or actinomycetes. Generally in eubacteria, improperly folded proteins with exposed hydrophobic residues are recognized by energy-dependent proteases (242,243). N-terminal domains including destabilizing residues of the N-end rule also specifically target proteins for degradation by the proteases such as ClpP

of *E. coli* (218,244). Proteins with destabilizing nonpolar C-termini are recognized by Clp and FtsH proteins in *E. coli* (245-250). This includes the *ssrA*-tagging system which adds nonpolar C-termini to damaged proteins produced from 3'-truncated mRNA (251), mRNAs which contain rare codons, and during tRNA scarcity (252). The SsrA-tag provides a means for the cell to identify these undesirable proteins for destruction by ClpXP and ClpAP proteases (245,246). Another pathway in eubacteria for targeting proteins for degradation is via the two-component response regulator RssB which in its phosphorylated form binds sigmaS (RpoS) and specifically targets this general stress response sigma factor for degradation by ClpXP (253). Stress apparently controls the RssB affinity for sigmaS through modification of RssB phosphorylation.

## 6. ARCHAEL GENOMICS

Complete genome sequences are available for the crenarchaeon *Aeropyrum pernix* K1 (140) as well as five euryarchaea including *Archaeoglobus fulgidus* (254), *Methanobacterium thermoautotrophicum* Delta H (255), *Methanococcus jannaschii* (256), *Pyrococcus abyssi* (141), and *Pyrococcus horikoshii* OT3 (142). The nearly complete sequences of the euryarchaeon *Pyrococcus furiosus* and crenarchaeon *Sulfolobus solfataricus* P2 genomes are also available (<http://www.ncbi.nlm.nih.gov/BLAST/unfinishedgenome.html>) (257). Future genome projects involving the korarchaea will also be of interest in understanding the evolutionary history of proteins, since these organisms have a close lineage to the root of the 16S rRNA phylogenetic tree and probably diverged prior to the crenarchaeal line (258).

### 6.1. 20S proteasome and PAN operons

The 20S proteasome and PAN gene sequences which are available provide insight into their phylogenetic distribution and operon organization. In general, these genes are unlinked and dispersed throughout the genomes of the archaea. This is in contrast to the genes encoding the related 20S proteasome and ARC proteins of the actinomycetes which typically form linked operons. Interestingly, the crenarchaeon *Pyrobaculum aerophilum* is an exception among the archaea with alpha- and beta-type 20S proteasome genes but no apparent PAN (Rpt-like) homolog (44).

In order to gain insight into the biological role of the archaeal proteasome, chromosomal regions of the 20S proteasome (*psmA* and *psmB*) and PAN (*pan*) genes were analyzed to identify potential polycistronic operons. The organization of genes surrounding *pan* is not highly conserved among the archaea (figure 5A). In a few of the archaea, *pan* is linked to a putative gene which is divergently transcribed and encodes a protein with similarity to eucaryal basal transcription factors which cluster to COG1813 (figure 5A) (COG, clusters of orthologous groups of proteins) (<http://www.ncbi.nlm.nih.gov/COG/>).

Proteasomes in the Archaea

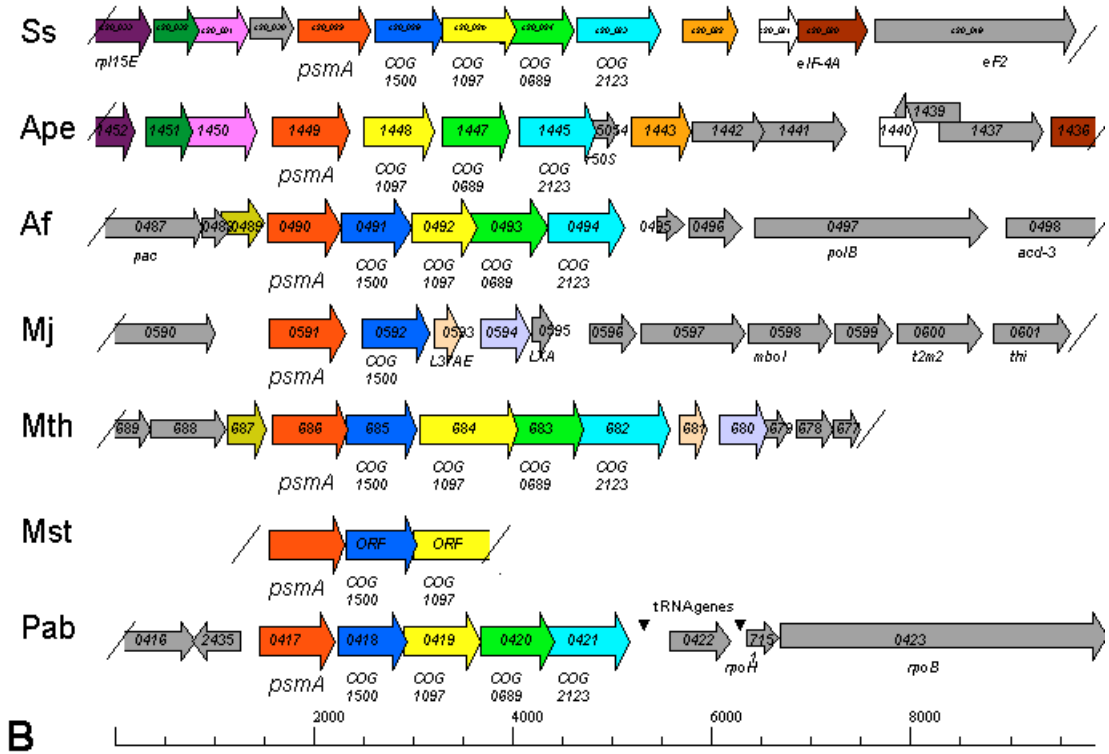
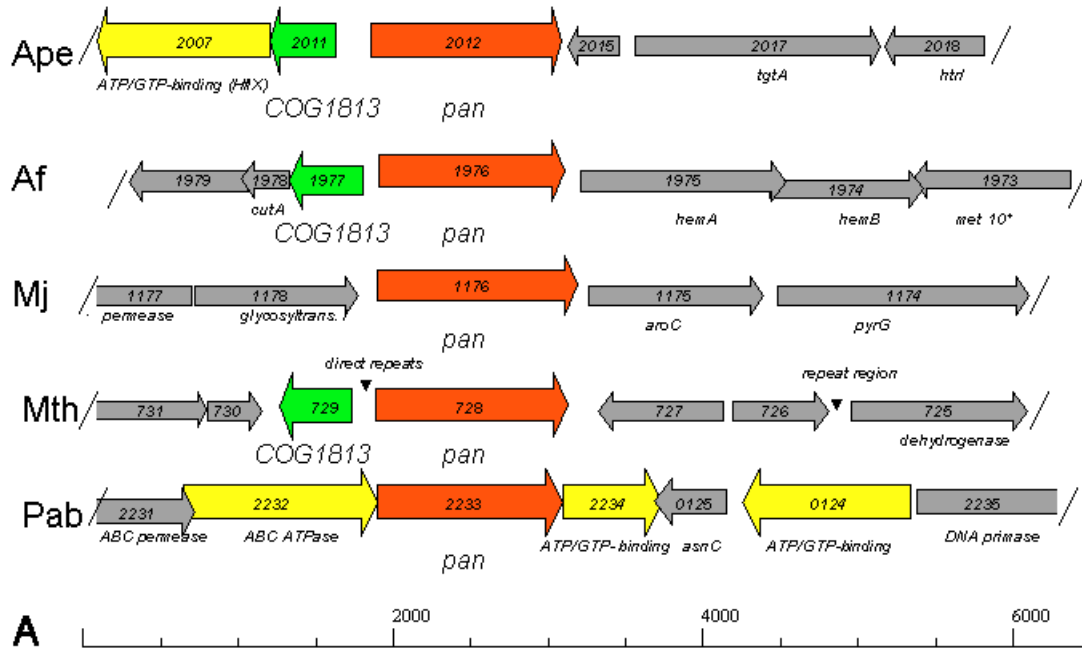

## Proteasomes in the Archaea

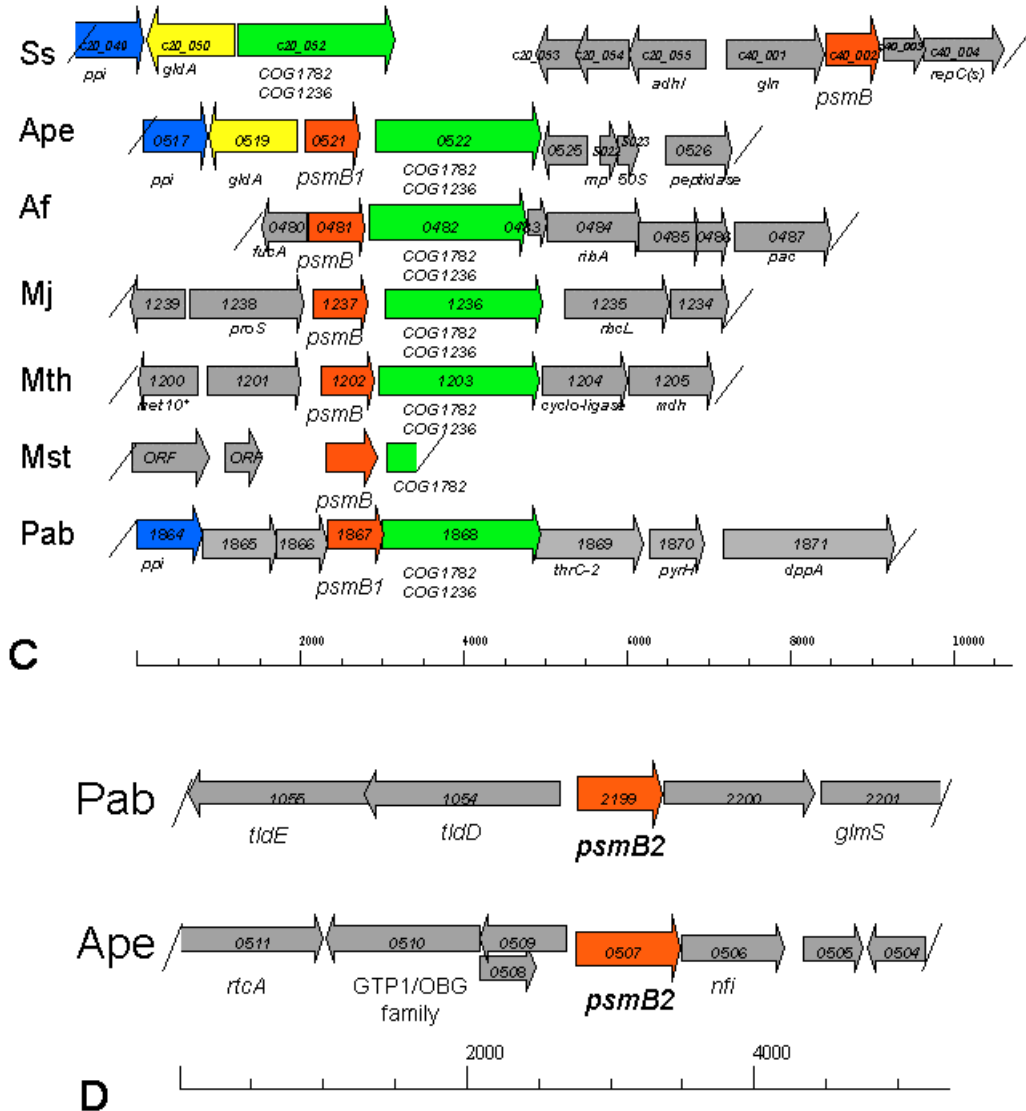

**Figure 5.** Putative operons encoding the proteasome-activating nucleotidase (PAN) protein and 20S proteasome subunits of the archaea. A. Archaeal genes linked to the *pan* gene encoding a 20S proteasome-activating nucleotidase. B. Archaeal genes linked to *psmA* encoding the common alpha subunit of 20S proteasomes of the archaea. C. Archaeal genes linked to *psmB* or *psmB1* encoding the common beta or beta1 subunit of 20S proteasomes of the archaea. D. Archaeal genes linked to *psmB2* encoding a second beta2 subunit of 20S proteasomes of *Aeropyrum* and *Pyrococcus* species. Arrows represent genes predicted from DNA sequence. Genbank protein identity numbers are within arrows. COG, Cluster of orthologous group of proteins described in text are indicated below putative genes. Abbreviations on left represent archaeal species, see figure 3. Scale in bp.

Most archaeal genes encoding the alpha-type proteasomal subunits (*psmA*) appear to be transcribed from a conserved operon which includes several uncharacterized genes. A gene immediately downstream of *psmA* is found in most archaea and encodes a protein of unknown function which clusters to COG1500 (figure 5B). Downstream of this, most archaea have a gene encoding a putative RNA-binding protein with an S1 domain of the COG1097 group (figure 5B). The next gene encodes a putative protein with similarity to the 3' exoribonucleolytic

trimming enzyme, ribonuclease PH of the COG0689 group, which catalyzes the final maturation of small RNA molecules in *E. coli* (259) (figure 5B). In most archaea, the final conserved gene which appears to be cotranscribed with *psmA* encodes a putative nuclease which is related to ribonuclease PH of the COG2123 group (figure 5B). The beta-type gene common to the archaea (*psmB* or *psmB1*) appears to be cotranscribed in an operon with a gene encoding a protein with an N-terminal RNA binding KH domain (COG 1782) and C-terminal Zn<sup>2+</sup>-dependent

## Proteasomes in the Archaea

hydrolase domain of the beta-lactamase superfamily (COG1236) (figure 5C). In contrast, the chromosomal regions linked to the genes of *Aeropyrum* and *Pyrococcus* encoding an additional beta-type subunit (*psmB2*) are not organized in a conserved operon (figure 5D).

Thus, it appears that genes encoding the alpha and beta subunits common to 20S proteasomes of the archaea are transcribed as separate operons which have conserved gene organization. Surprisingly, the majority of genes predicted to be co-transcribed with *psmA* or *psmB* have high similarity to proteins involved in RNA processing and binding. Thus, the archaeal proteasome may associate with or regulate the turnover of proteins which bind to and modify RNA. In eucaryotes, the proteasome has been implicated in repression of mRNA translation (260), pre-tRNA 5' processing endonuclease activity (261), and aminoacyl transferase activity (262). Small cytoplasmic RNA molecules have also been found associated with eucaryal proteasomes (263,264). Interestingly, the CCT-TRiC (Hsp60) chaperone of the archaeon *Sulfolobus solfataricus* is also an RNA-binding protein that participates in ribosomal RNA processing (265). Whether specific RNA molecules are an integral part of the proteasome or reflect any of the physiological roles of this complex is unclear (266).

### 6.2. Additional energy-dependent proteases

Based on genome sequence analysis many additional self-compartmentalized proteases and AAA<sup>+</sup> proteins are predicted to be encoded in the archaea including the: 1) Rpt/FtsH ATPase, 2) Lon protease, 3) Clp ATPase, and 4) HtrA (DegP) protease.

#### 6.2.1. Rpt/FtsH ATPase

A putative ATPase found in a variety of archaea has similarity to the energy-dependent FtsH protease and Rpt subunits of the 26S proteasome. The protein clusters to COG1223 and has motifs typical of AAA<sup>+</sup> proteins including those for binding Mg<sup>2+</sup>, RNA/DNA, ATP, and guanine rings (180). However, the Zn<sup>2+</sup>-dependent proteolytic active-site and N-terminal transmembrane region of FtsH proteases (267) are not conserved. Therefore, it is likely that the archaeal Rpt/FtsH-like ATPase is cytoplasmic and does not directly hydrolyze peptide-bonds but instead may act as an ATP-dependent unfoldase in protein degradation and/or as a molecular chaperone in protein folding.

#### 6.2.2. Lon Protease

Archaea genomes also encode a putative protein which clusters to COG1067 and has significant identity to the energy-dependent Lon protease characterized from the cytosol of eubacteria and the chloroplast and mitochondria of eucaryotes. The mitochondrial Lon has recently been shown to form a ring shaped complex with seven flexible subunits (268) which, in combination with biochemical studies, suggests a self-compartmentalization of the active sites. The Ser residue which acts as a nucleophile in peptide bond hydrolysis as well as residues involved in ATP binding and hydrolysis (269-272) are conserved in the archaeal Lon protein suggesting that it may catalyze the

energy-dependent hydrolysis of substrate proteins. Surprisingly, however, the N-terminus of the archaeal Lon has two putative transmembrane domains suggesting it is associated with the membrane.

#### 6.2.3. Clp ATPase and HtrA (DegP)

ClpP proteases are not present in the archaea; however, *M. thermoautotrophicum* appears to be one of the few archaea encoding a Clp-like ATPase (gene identification number MTH284) (255). This putative Clp ATPase may function as a chaperone and/or associate with non-ClpP proteases in the moderately thermophilic methanogen. *M. thermoautotrophicum* also appears to encode an HtrA(DegP) protease (gene identification number MTH1813). In eubacteria, HtrA is a periplasmic, heat shock inducible serine protease (273) which is indispensable at elevated temperatures (274,275) and participates in defense against oxidative stress in *E. coli* (276). Recently, the *E. coli* HtrA was identified as forming a self-compartmentalized structure similar to other energy-dependent proteases (277). Although the openings at the ends of its cylindrical structure were narrower than the openings of GroEL, they were larger than those of the 20S proteasome, ClpP, and HslV (277). Because the periplasmic space is believed to be depleted of ATP, it is speculated that HtrA may not associate with energy-dependent unfoldases and instead hydrolyzes proteins denatured by stress. Although the archaeal HtrA protein has conserved residues required for proteolytic activity, it does not have conserved signal sequences. Thus, the archaeal HtrA may instead form a self-compartmentalized protease in the cytosol which requires association of AAA<sup>+</sup>-type protein(s) for hydrolysis of proteins.

## 7. ROLE OF PROTEASOMES IN STRESS RESPONSES

Survival of cells is critically dependent on their ability to adapt to constantly occurring changes in their natural environment *e.g.* temperature shifts, oxidative damage, and changes in nutrient availability. This ability to rapidly respond to stress and other environmental changes is vital to cell survival. Proteolysis is considered to be a central mechanism in stress responses to eliminate damaged proteins in addition to targeting proteins in pathways which are necessary for normal growth but which may be harmful under stressful conditions (278).

### 7.1. Eucaryal 26S proteasomes and stress

The 26S proteasome participates in nearly all intracellular protein degradation required for eucaryal cell function including bulk turnover of proteins as well as the targeted hydrolysis of specific proteins through the ubiquitin-mediated pathway (42). The central role of this protease in eucaryotic cell physiology is highlighted by mutagenesis studies in yeast which reveal that many of the subunits of the 26S proteasome are essential for life (1,6). The ubiquitin-proteasome pathway has specific functions critical for cell survival such as regulation of the cell cycle, class I antigen processing, signal transduction, sporulation, DNA repair, heat shock, heavy metal resistance, and degradation of abnormal proteins (5,6,215).

## Proteasomes in the Archaea

An early indication that there was a relationship between the ubiquitin system and stress was through investigation of a mammalian mutant cell line ts85 which has a temperature-sensitive mutation in an E1 ubiquitin-activating enzyme (279,280). These cells exhibited strong defects in the degradation of short-lived and abnormal proteins damaged by heat or amino-acid analogs. These results are consistent with the observed increase in ubiquitin synthesis followed by a burst of protein ubiquitination which ultimately results in a depletion of free ubiquitin in the cytosol during stress (281,282). Polyubiquitin genes such as *UBI4* of yeast are strongly induced by a variety of environmental stresses including: heat and cold shock, nutrient depletion, DNA-damaging agents, oxidizing agents, and heavy metals (282-286). The transcriptional response of *UBI4* is regulated by multiple independent pathways and is likely to be the primary mechanism for increasing the pool of ubiquitin for degradation of stress-damaged proteins (287). Genes encoding the deubiquitinating enzymes Ubp4/Doa4 and Ubp14 are also needed for stress-resistance and sporulation in yeast in order to increase the ubiquitin pool (6,288). The transcription of several genes encoding E2 ubiquitin conjugating enzyme are stress-inducible including: *UBC2/RAD6* by ultraviolet light, DNA damaging agents, or during sporulation (289); *UBC4* by heat shock (290); *UBC1* during stationary-phase growth (291); and *UBC5* by heat-shock, cadmium, or stationary-phase growth (290). These results are corroborated by mutagenesis studies which reveal that *UBC2/RAD6* is required for DNA repair and sporulation (292); *UBC4* and *UBC5* are required for bulk degradation of short-lived and abnormal proteins (290); *UBC5* is also essential for sporulation and survival during stress (*i.e.* heat shock, amino-acid analogs, and cadmium); and *UBC7* is needed for cadmium resistance (5). Heat stress, amino-acid analogs, ethanol, and heavy metals are all damaging to proteins and are likely to expose structural elements (*e.g.* hydrophobic patches) which are recognized by E2/E3s for targeting damaged proteins to the proteasome for destruction.

Based on mutagenesis studies in yeast, several subunits of the 26S proteasome including the alpha5, beta1, beta4, beta5, and beta7 subunits of the 20S proteasome and the non-ATPase subunit Rpn2 (Sen3) of the 19S cap appear to be linked to stress responses (6). In addition, yeast genomic analysis using DNA chip technology reveals a 5 to 10 fold increase in mRNA transcripts of not only ubiquitin but also the Rpn1 (non-ATPase) and beta1 subunits of the 26S proteasome after exposure to a DNA-damaging agent (23). Furthermore, energy-dependent 26S proteasome assembly is enhanced in cell lysate prepared from nutrient depleted, heat-stressed yeast cells versus non-stressed cells (293). In some cancer cell lines, the proteasome is localized to the nucleus after stress (*e.g.* 294) presumably by the exposure of nuclear localization sequences of the 20S proteasome (295).

Addition of specific proteasome inhibitors (*e.g.* MG132, lactacystin) to cells is often associated with an increased synthesis of conserved heat-shock proteins even in the absence of stress. It is difficult to know whether

these responses are due to loss of specific proteasome function or to general accumulation of defective protein aggregates in the cell which triggers the response. Exposure of kidney cells to proteasome inhibitors prevents the degradation of short-lived proteins and increases the levels of cytosolic Hsps (Hsp70 and polyUb) and ER chaperones (BiP, ERp72, and Grp94) which results in thermotolerance (15). In yeast, proteasome inhibitors stimulate the synthesis of trehalose and Hsps which confer thermotolerance (296). Treatment of certain tumor cell lines with proteasome inhibitors leads to an increase in activity of c-Jun N-terminal kinase (JNK1) which is known to initiate apoptosis in response to certain stresses (297). The two heat-shock-inducible transcription factors, HSF1 and HSF3, as well as the development-related transcription factor HSF2 are all activated after the treatment of avian cells with proteasome inhibitors (298).

Several heat-shock proteins (Hsps) appear to cooperate with the ubiquitin-proteasome pathway to maintain the conformation of the 20S proteasome, modify 20S proteasome peptidase activities, and assist in the recognition of damaged proteins for degradation by the 20S proteasome. Hsp90 copurifies with the 20S proteasome from 1-month but not 2-year-old bovine lenses suggesting an age-dependent, specific interaction (299). In addition, Hsp90 protects 20S proteasomes from oxidative damage (300) and specifically modifies 20S proteasome peptidase activity via non-competitive inhibition with chymotrypsin-like substrates (301). Hsp70 also appears to directly interact with the 20S proteasome, based on the finding that a yeast Hsp70 gene is a multi-copy suppressor of a temperature-sensitive growth mutation in the alpha2 proteasomal gene (302). Hsp70 proteins may facilitate energy-dependent protein degradation by the 20S proteasome as well as by the mitochondrial mAAA (FtsH) and PIM1 (Lon) proteases (303). Mutagenesis studies also demonstrate that the C-type cyclin Ume3 which represses *SSA1* (Hsp70 family) transcription is rapidly destroyed by the ubiquitin-proteasome pathway in cells exposed to stresses such as ethanol, heat shock, oxidative stress, or carbon starvation (304).

The cooperation of molecular chaperones with energy-dependent proteolytic pathways has also been observed in prokaryotes. The DnaK (Hsp70) chaperone with cochaperone DnaJ (Hsp40) and GrpE (nucleotide exchange factor) are required for the hydrolysis of incorrectly folded proteins by the Lon protease in *E. coli* (305). GroEL, GroES, and trigger factor also play a role in the selective and rapid degradation of abnormal proteins by the *E. coli* ClpP protease (306-308). It is likely that many of these chaperones are needed to prevent damaged proteins from forming harmful, insoluble amyloids or aggregates which are no longer accessible for hydrolysis by energy-dependent proteases.

## 7.2. Eubacterial HslUV proteases and stress

The proteasome-related HslUV protease, found in most eubacteria, is encoded by the heat shock inducible *hslUV* operon (22). *In vitro*, HslUV functions as an ATP-dependent protease and protein-activated ATPase toward denatured substrates (309). *In vivo*, HslUV is involved in



## Proteasomes in the Archaea

the overall proteolysis of misfolded proteins in *E. coli* (310) and regulates the heat-shock response by controlling the hydrolysis of sigma factor 32 (RpoH) in a synergistic mechanism with other ATP-dependent proteases (311). A transient increase in sigma32 then activates transcription of heat shock genes in *E. coli*. The HslUV protease also suppresses the SOS-mediated inhibition of cell division by its ability to degrade SulA, an inhibitor of the FtsZ cell division protein (312).

### 7.3. Procaryotic 20S proteasome and AAA<sup>+</sup> proteins and stress

Little is known about the biological significance of 20S proteasomes or Rpt-like-AAA<sup>+</sup> proteins in the archaea or actinomycetes. The role of procaryotic 20S proteasomes in protein degradation has not been demonstrated *in vivo* and substrate proteins have not been identified. In analogy to the eucaryal proteasome it is possible that the procaryotic enzyme plays an active role in mediating stress responses of the cell. In general, most proteasomes purified from eucaryotes or procaryotes are stable at temperatures above the optimum for growth and are resistant to damage by oxidizing agents suggesting that the enzyme complex is stable after exposure to stress (*e.g.* 34,301,313).

In the actinomycetes, the levels of the 20S proteasome subunits do not increase after cells are exposed to heat shock (13). In addition, two-dimensional electrophoresis reveals that the ARC (AAA<sup>+</sup>) protein is expressed in a relatively small amount, and its levels are independent of the growth temperature of the organism from 4 to 34 EC (45). Knockout mutations of alpha- and beta-type 20S proteasomal genes in the eubacterium *Mycobacterium smegmatis* result in no discernable phenotypic changes including: response to stresses such as heat shock, nutrient depletion, ethanol shock, heavy metals, amino-acid analogs, and osmotic shock (314). It is possible that other proteases compensate for the loss of proteasome function in these mutant strains. This has been observed for proteasome inhibitor-adapted eucaryotic cells which exhibit enhanced tripeptidyl peptidase II (TPPII) activity catalyzed by a large rod-shaped protease which appears to substitute for some metabolic functions of the proteasome (315). The HslUV protease also has a substrate specificity overlapping that of the Lon protease in *E. coli* (316).

Many archaea grow optimally in what are considered to be >extreme= environments such as high/low temperature, high/low pH, high salinity, high pressure, and absence of oxygen. However, even extremophiles exhibit stress responses and acquire thermotolerance after brief exposure to heat shock temperatures (317,318). To investigate the role of the archaeal proteasome in stress, *T. acidophilum* cells were incubated with a tri-peptide vinyl sulfone inhibitor which inactivated about 80% of the 20S proteasome beta subunits through covalent modification of the N-terminal Thr active site nucleophile (319). This partial inhibition of 20S proteasome activity significantly reduced the ability of cells to overcome heat shock (319). These results suggest that with only about 20% functional 20S proteasomes, *T. acidophilum* is unable to overcome an

increased level of heat-damaged proteins. It is likely that these damaged proteins formed intracellular aggregates or inclusion bodies which inhibited cell growth. Analysis of *H. volcanii* (S. J. Kaczowka, H. L. Wilson, and J. A. Maupin-Furlow, unpublished) reveals that during normal growth the levels of the alpha1 proteasome protein are constitutive; whereas, the levels of the alpha2 protein increase during stationary phase. After heat shock or addition of canavanine, the levels of 20S proteasome protein and mRNA transcripts are increased. Although further studies are needed, these studies suggest that the 20S proteasome may play a role in the stress responses of the archaeal cell.

## 8. PERSPECTIVE

Obviously, there is little known regarding the physiological role of the 20S proteasome in the archaea or actinomycetes. We are encouraged by the recent analysis of 20S proteasomes and PAN proteins from the haloarchaeon *H. volcanii* (34) as well as the methanoarchaeon *Methanococcus maripaludis* (H. L. Wilson and J. A. Maupin-Furlow, unpublished). Both of these organisms have fairly well established genetic systems for the analysis of proteasome function *in vivo*. This includes efficient transformation of spheroplasts, random mutagenesis and complementation strategies, shuttle and expression vectors, transcriptional reporter systems, high-resolution genomic maps, and a set of overlapping cosmid clones covering the genome (*e.g.* 320,321). It will be interesting to integrate the detailed information on the biochemical and biophysical properties of 20S proteasome and Rpt-like (AAA<sup>+</sup>) proteins with studies focused on understanding how these elaborate complexes function in the archaeal cell.

## 9. ACKNOWLEDGMENTS

We are greatly indebted to H. C. Aldrich and D. Williams for their help with transmission electron microscopy of 20S proteasome particles. We thank M. C. Bewley and J. M. Flanagan at the Brookhaven National Laboratories for supportive discussions as well as generating a detailed structural model of the *M. thermophila* 20S proteasome. We appreciate J. Hurlbert for his generous assistance in computational software programs. We also thank S. Wickner, M. R. Maurizi, and S. Gottesman for assistance with developing images which compare the energy-dependent ClpAP protease and 26S proteasome. We also thank C. Furlow for technical assistance with the manuscript. This work was supported in part by the National Institutes of Health award R01GM57498 and Florida Agricultural Experiment Station (Journal Series R07648).

## 10. REFERENCES

1. Hilt, W. & D.H. Wolf: Proteasomes: destruction as a programme. *Trends Biochem Sci* 21, 96-102 (1996)

## Proteasomes in the Archaea

2. Goldberg, A.L. & A.C. St. John: Intracellular protein degradation in mammalian and bacterial cells: part 2. *Annu Rev Biochem* 45, 747-803 (1976)
3. Maurizi, M.R.: Proteases and protein degradation in *Escherichia coli*. *Experientia* 48, 178-201 (1992)
4. Gottesman, S.: Proteases and their targets in *Escherichia coli*. *Annu Rev Genet* 30, 465-506 (1996)
5. Jentsch, S.: The ubiquitin-conjugation system. *Annu Rev Genet* 26, 179-207 (1992)
6. Hochstrasser, M.: Ubiquitin-dependent protein degradation. *Annu Rev Genet* 30, 405-439 (1996)
7. Gottesman, S. & M.R. Maurizi: Regulation by proteolysis: energy-dependent proteases and their targets. *Microbiol Rev* 56, 592-621 (1992)
8. Goldberg, A.L.: Degradation of abnormal proteins in *Escherichia coli*. *Proc Natl Acad Sci USA* 69, 422-426 (1972)
9. Schimke, R.T.: Control of enzyme levels in mammalian tissues. *Adv Enzymol* 37, 135-187 (1973)
10. Thompson, M.W., S.K. Singh & M.R. Maurizi: Processive degradation of proteins by the ATP-dependent Clp protease from *Escherichia coli*: requirement for the multiple array of active sites in ClpB but not ATP hydrolysis. *J Biol Chem* 269, 18209-18215 (1994)
11. Kisselev, A.F., T.N. Akopian, K.M. Woo & A.L. Goldberg: The sizes of peptides generated from protein by mammalian 26 and 20 S proteasomes. Implications for understanding the degradative mechanism and antigen presentation. *J Biol Chem* 274, 3363-3371 (1999)
12. Akopian, T.N., A.F. Kisselev & A.L. Goldberg: Processive degradation of proteins and other catalytic properties of the proteasome from *Thermoplasma acidophilum*. *J Biol Chem* 272, 1791-1798 (1997)
13. De Mot, R., I. Nagy, J. Walz & W. Baumeister: Proteasomes and other self-compartmentalizing proteases in prokaryotes. *Trends Microbiol* 7, 88-92 (1999)
14. Lupas, A., J.M. Flanagan, T. Tamura & W. Baumeister: Self-compartmentalizing proteases. *Trends Biochem Sci* 22, 399-404 (1997)
15. Bush, K.T., A.L. Goldberg & S.K. Nigam: Proteasome inhibition leads to a heat-shock response, induction of endoplasmic reticulum chaperones, and thermotolerance. *J Biol Chem* 272, 9086-9092 (1997)
16. Kroh, H.E. & L.D. Simon: The ClpP component of Clp protease is the sigma32-dependent heat shock protein F21.5. *J Bacteriol* 172, 6026-6034 (1990)
17. Gottesman, S., W.P. Clark, V. de Crecy-Lagard & M.R. Maurizi: ClpX, an alternative subunit for the ATP-dependent Clp protease of *Escherichia coli*. Sequence and *in vivo* activities. *J Biol Chem* 268, 22618-22626 (1993)
18. Phillips, T.A., R.A. VanBogelen & F.C. Neidhardt: *lon* gene product of *Escherichia coli* is a heat-shock protein. *J Bacteriol* 159, 283-287 (1984)
19. Goff, S.A., L.P. Casson & A.L. Goldberg: Heat shock regulatory gene *htpR* influences rates of protein degradation and expression of the *lon* gene in *Escherichia coli*. *Proc Natl Acad Sci USA* 81, 6647-6651 (1984)
20. Hecker, M., W. Schumann & U. Volker: Heat-shock and general stress response in *Bacillus subtilis*. *Mol Microbiol* 19, 417-428 (1996)
21. Herman, C., D. Thevenet, R. D'Ari & P. Bouloc: Degradation of sigma32, the heat shock regulator in *Escherichia coli*, is governed by HflB. *Proc Natl Acad Sci USA* 92, 3516-3520 (1995)
22. Chuang, S.E., V. Burland, G. Plunkett, D.L. Daniels & F.R. Blattner: Sequence analysis of four new heat-shock genes constituting the *hslTS/ibpAB* and *hslVU* operons in *Escherichia coli*. *Gene* 134, 1-6 (1993)
23. Jelinsky, S.A. & L.D. Samson: Global response of *Saccharomyces cerevisiae* to an alkylating agent. *Proc Natl Acad Sci USA* 96, 1486-1491 (1999)
24. Baumeister, W., J. Walz, F. Zühl & E. Seemüller: The proteasome: paradigm of a self-compartmentalizing protease. *Cell* 92, 367-380 (1998)
25. Baumeister, W., Z. Cejka, M. Kania & E. Seemüller: The proteasome: a macromolecular assembly designed to confine proteolysis to a nanocompartment. *Biol Chem* 378, 121-130 (1997)
26. Wickner, S., M.R. Maurizi & S. Gottesman: Posttranslational quality control: folding, refolding, and degrading proteins. *Science* 286, 1888-1893 (1999)
27. Gottesman, S., M.R. Maurizi & S. Wickner: Regulatory subunits of energy-dependent proteases. *Cell* 91, 435-438 (1997)
28. Schmidt, M., A. N. Lupas & D. Finley: Structure and mechanism of ATP-dependent proteases. *Curr Opin Chem Biol* 3, 584-591 (1999)
29. Lupas, A., F. Zühl, T. Tamura, S. Wolf, I. Nagy, R. De Mot & W. Baumeister: Eubacterial proteasomes. *Mol Biol Rep* 24, 125-131 (1997)
30. Arcangeletti, C., R. Sutterlin, U. Aebi, F. Deconto, S. Missorini, C. Chezzi & K. Scherrer: Visualization of prosomes (MCP-proteasomes), intermediate filament and actin networks by "instantaneous fixation" preserving the

## Proteasomes in the Archaea

- cytoskeleton. *J Struct Biol* 119, 35-58 (1997)
31. Peters, J.M., W. W. Franke & J. A. Kleinschmidt: Distinct 19 S and 20 S subcomplexes of the 26 S proteasome and their distribution in the nucleus and the cytoplasm. *J Biol Chem* 269, 7709-7718 (1994)
32. Rivett, A.J.: Intracellular distribution of proteasomes. *Curr Opin Immunol* 10, 110-114 (1998)
33. Maupin-Furlow, J.A. & J. G. Ferry: A proteasome from the methanogenic archaeon *Methanosarcina thermophila*. *J Biol Chem* 270, 28617-28622 (1995)
34. Wilson, H.L., H. C. Aldrich & J. A. Maupin-Furlow: Halophilic 20S proteasomes of the archaeon *Haloflex volcanii*: purification, characterization, and gene sequence analysis. *J Bacteriol* 181, 5814-5824 (1999)
35. Dahlmann, B., F. Kopp, L. Kuehn, B. Niedel, G. Pfeifer, R. Hegerl & W. Baumeister: The multicatalytic proteinase (prosome) is ubiquitous from eukaryotes to archaeobacteria. *FEBS Lett* 251, 125-131 (1989)
36. Bauer, M.W., S. B. Halio & R. M. Kelly: Purification and characterization of a proteasome from the hyperthermophilic archaeon *Pyrococcus furiosus*. *Appl Environ Microbiol* 63, 1160-1164 (1997)
37. Tamura, T., I. Nagy, A. Lupas, F. Lottspeich, Z. Cejka, G. Schoofs, K. Tanaka, R. De Mot & W. Baumeister: The first characterization of a eubacterial proteasome: the 20S complex of *Rhodococcus*. *Curr Biol* 5, 766-774 (1995)
38. Nagy, I., T. Tamura, J. Vanderleyden, W. Baumeister & R. De Mot: The 20S proteasome of *Streptomyces coelicolor*. *J Bacteriol* 180, 5448-5453 (1998)
39. Pouch, M.N., B. Cournoyer & W. Baumeister: Characterization of the 20S proteasome from the actinomycete *Frankia*. *Mol Microbiol* 35, 368-377 (2000)
40. Wenzel, T. & W. Baumeister: Conformational constraints in protein degradation by the 20S proteasome. *Nat Struct Biol* 2, 199-204 (1995)
41. Yang, Y., K. Früh, K. Ahn & P.A. Peterson: *In vivo* assembly of the proteasomal complexes, implications for antigen processing. *J Biol Chem* 270, 27687-27964 (1995)
42. Coux, O., K. Tanaka & A.L. Goldberg: Structure and functions of the 20S and 26S proteasomes. *Annu Rev Biochem* 65, 801-847 (1996)
43. Wilson, H.L., M.S. Ou, H.C. Aldrich & J.A. Maupin-Furlow: Biochemical and physical properties of the *Methanococcus jannaschii* 20S proteasome and PAN, a homolog of the ATPase (Rpt) subunits of the eucaryal 26S proteasome. *J Bacteriol* 182, 1680-1692 (2000)
44. Zwickl, P., D. Ng, K.M. Woo, H.-P. Klenk & A.L. Goldberg: An archaeobacterial ATPase, homologous to ATPases in the eukaryotic 26S proteasome, activates protein breakdown by 20S proteasomes. *J Biol Chem* 274, 26008-26014 (1999)
45. Wolf, S., I. Nagy, A. Lupas, G. Pfeifer, Z. Cejka, S.A. Müller, A. Engel, R. De Mot & W. Baumeister: Characterization of ARC, a divergent member of the AAA ATPase family from *Rhodococcus erythropolis*. *J Mol Biol* 277, 13-25 (1998)
46. Coux, O., H.G. Nothwang, I.S. Pereira, F.R. Targa, F. Bey & K. Scherrer: Phylogenetic relationships of the amino acid sequences of prosome (proteasome, MCP) subunits. *Mol Gen Genet* 245, 769-780 (1994)
47. Zwickl, P., A. Grizwa, G. Pühler, B. Dahlmann, F. Lottspeich & W. Baumeister: Primary structure of the *Thermoplasma* proteasome and its implications for the structure, function, and evolution of the multicatalytic proteinase. *Biochemistry* 31, 964-972 (1992)
48. Grizwa, A., W. Baumeister, B. Dahlmann & F. Kopp: Localization of subunits in proteasomes from *Thermoplasma acidophilum* by immunoelectron microscopy. *FEBS Lett* 290, 186-190 (1991)
49. Lupas, A., A. J. Koster, J. Walz & W. Baumeister: Predicted secondary structure of the 20S proteasome and model structure of the putative peptide channel. *FEBS Lett* 354, 45-49 (1994)
50. Schauer, T.M., M. Nesper, M. Kehl, F. Lottspeich, A. Muller-Taubenberger, G. Gerisch & W. Baumeister: Proteasomes from *Dictyostelium discoideum*: characterization of structure and function. *J Struct Biol* 111, 135-147 (1993)
51. Kopp, F., B. Dahlmann & K.B. Hendil: Evidence indicating that the human proteasome is a complex dimer. *J Mol Biol* 229, 14-19 (1993)
52. Kopp, F., P. Kristensen, K.B. Hendil, A. Johnsen, A. Sobek & B. Dahlmann: The human proteasome subunit HsN3 is located in the inner rings of the complex dimer. *J Mol Biol* 248, 264-272 (1995)
53. Kopp, F., K.B. Hendil, B. Dahlmann, P. Kristensen, A. Sobek & W. Uerkvitz: Subunit arrangement in the human 20S proteasome. *Proc Natl Acad Sci USA* 94, 2939-2944 (1997)
54. Löwe, J., D. Stock, B. Jap, P. Zwickl, W. Baumeister & R. Huber: Crystal structure of the 20S proteasome from the archaeon *T. acidophilum* at 3.4 Å resolution. *Science* 268, 533-539 (1995)
55. Groll, M., L. Ditzel, J. Löwe, D. Stock, M. Bochtler, H.D. Bartunik & R. Huber: Structure of 20S proteasome from yeast at 2.4 Å resolution. *Nature* 386, 463-471 (1997)
56. Weissman, J.S., P.B. Sigler & A.L. Horwich: From the cradle to the grave: ring complexes in the life of a protein. *Science* 268, 523-524 (1995)

## Proteasomes in the Archaea

57. Zwickl,P., G. Pfeifer, F. Lottspeich, F. Kopp, B. Dahlmann & W. Baumeister: Electron microscopy and image analysis reveal common principles of organization in two large protein complexes: groEL-type proteins and proteasomes. *J Struct Biol* 103, 197-203 (1990)
58. Xu,Z., A.L. Horwich & P.B. Sigler: The crystal structure of the asymmetric GroEL-GroES-(ADP)<sub>7</sub> chaperonin complex. *Nature* 388, 741-750 (1997)
59. Boisvert,D.C., J. Wang, Z. Otwinowski, A.L. Horwich & P.B. Sigler: The 2.4 Å crystal structure of the bacterial chaperonin GroEL complexed with ATP-gamma-S. *Nat Struct Biol* 3, 170-177 (1996)
60. Braig,K., Z. Otwinowski, R. Hegde, D.C. Boisvert, A. Joachimiak, A.L. Horwich & P.B. Sigler: The crystal structure of the bacterial chaperonin GroEL at 2.8 Å. *Nature* 371, 578-586 (1994)
61. Maupin-Furlow,J.A., H.C. Aldrich & J.G. Ferry: Biochemical characterization of the 20S proteasome from the methanoarchaeon *Methanosarcina thermophila*. *J Bacteriol* 180, 1480-1487 (1998)
62. Dahlmann,B., L. Kuehn, A. Grizwa, P. Zwickl & W. Baumeister: Biochemical properties of the proteasome from *Thermoplasma acidophilum*. *Eur J Biochem* 208, 789-797 (1992)
63. Wenzel,T.& W. Baumeister: *Thermoplasma acidophilum* proteasomes degrade partially unfolded and ubiquitin-associated proteins. *FEBS Lett* 326, 215-218 (1993)
64. Pacifici,R.E., Y. Kono & K.J. Davies: Hydrophobicity as the signal for selective degradation of hydroxyl radical-modified hemoglobin by the multicatalytic proteinase complex, proteasome. *J Biol Chem* 268, 15405-15411 (1993)
65. Sacchetta,P., P. Battista, S. Santarone & D. Di Cola: Purification of human erythrocyte proteolytic enzyme responsible for degradation of oxidant-damaged hemoglobin. Evidence for identifying as a member of the multicatalytic proteinase family. *Biochim Biophys Acta* 1037, 337-343 (1990)
66. Pacifici,R.E., D.C. Salo & K.J. Davies: Macroxyproteinase (M.O.P.): a 670 kDa proteinase complex that degrades oxidatively denatured proteins in red blood cells. *Free Radic Biol Med* 7, 521-536 (1989)
67. Fagan,J.M., L. Waxman & A.L. Goldberg: Red blood cells contain a pathway for the degradation of oxidant-damaged hemoglobin that does not require ATP or ubiquitin. *J Biol Chem* 261, 5705-5713 (1986)
68. Dick,L.R., C. Aldrich, S.C. Jameson, C.R. Moomaw, B.C. Pramanik, C.K. Doyle, G.N. DeMartino, M.J. Bevan, J.M. Forman & C.A. Slaughter: Proteolytic processing of ovalbumin and beta-galactosidase by the proteasome to a yield antigenic peptides. *J Immunol* 152, 3884-3894 (1994)
69. Mykles,D.L.& M.F. Haire: Sodium dodecyl sulfate and heat induce two distinct forms of lobster muscle multicatalytic proteinase: the heat-activated form degrades myofibrillar proteins. *Arch Biochem Biophys* 288, 543-551 (1991)
70. Cardozo,C., A. Vinitzky, M.C. Hidalgo, C. Michaud & M. Orłowski: A 3,4-dichloroisocoumarin-resistant component of the multicatalytic proteinase complex. *Biochemistry* 31, 7373-7380 (1992)
71. Kisselev,A.F., T.N. Akopian & A.L. Goldberg: Range of sizes of peptide products generated during degradation of different proteins by archaeal proteasomes. *J Biol Chem* 273, 1982-1989 (1998)
72. McGuire,M.J., M.L. McCullough, D.E. Croall & G.N. DeMartino: The high molecular weight multicatalytic proteinase, macropain, exists in a latent form in human erythrocytes. *Biochim Biophys Acta* 995, 181-186 (1989)
73. Arribas,J., P. Arizti & J.G. Castaño: Antibodies against the C2 COOH-terminal region discriminate the active and latent forms of the multicatalytic proteinase complex. *J Biol Chem* 269, 12858-12864 (1994)
74. Weitman,D.& J.D. Etlinger: A monoclonal antibody that distinguishes latent and active forms of the proteasome (multicatalytic proteinase complex). *J Biol Chem* 267, 6977-6982 (1992)
75. Gardrat,F., B. Fraigneau, V. Montel, J. Raymond & J.L. Azanza: Effect of high hydrostatic pressures on 20S proteasome activity. *Eur J Biochem* 262, 900-906 (1999)
76. Hegerl,R., G. Pfeifer, G. Pühler, B. Dahlmann & W. Baumeister: The three-dimensional structure of proteasomes from *Thermoplasma acidophilum* as determined by electron microscopy using random conical tilting. *FEBS Lett* 283, 117-121 (1991)
77. Bochtler,M., L. Ditzel, M. Groll, C. Hartmann & R. Huber: The proteasome. *Annu Rev Biophys Biomol Struct* 28, 295-317 (1999)
78. Wang,J., J.A. Hartling & J.M. Flanagan: The structure of ClpP at 2.3 Å resolution suggests a model for ATP-dependent proteolysis. *Cell* 91, 447-456 (1997)
79. Bochtler,M., L. Ditzel, M. Groll & R. Huber: Crystal structure of heat shock locus V (HslV) from *Escherichia coli*. *Proc Natl Acad Sci USA* 94, 6070-6074 (1997)
80. Orłowski,M., C. Cardozo & C. Michaud: Evidence for the presence of five distinct proteolytic components in the pituitary multicatalytic proteinase complex. Properties of two component cleaving bonds on the carboxyl side of branched chain and small neutral amino acids. *Biochemistry* 32, 1563-1572 (1993)
81. Cardozo,C.: Catalytic components of the bovine pituitary multicatalytic proteinase complex (proteasome). *Enzyme Protein* 47, 296-305 (1993)

## Proteasomes in the Archaea

82. Rivett, A.J.: Proteasomes: multicatalytic proteinase complexes. *Biochem J* 291, 1-10 (1993)
83. Arendt, C.S. & M. Hochstrasser: Identification of the yeast 20S proteasome catalytic centers and subunit interactions required for active-site formation. *Proc Natl Acad Sci USA* 94, 7156-7161 (1997)
84. Dick, T.P., A.K. Nussbaum, M. Deeg, W. Heinemeyer, M. Groll, M. Schirle, W. Keilholz, S. Stevanovic, D.H. Wolf, R. Huber *et al.*: Contribution of proteasomal beta-subunits to the cleavage of peptide substrates analyzed with yeast mutants. *J Biol Chem* 273, 25637-25646 (1998)
85. Heinemeyer, W., A. Gruhler, V. Möhrle, Y. Mahé & D.H. Wolf: *PRE2*, highly homologous to the human major histocompatibility complex-linked *RING10* gene, codes for a yeast proteasome subunit necessary for chrymotryptic activity and degradation of ubiquitinated proteins. *J Biol Chem* 268, 5115-5120 (1993)
86. Finley, D., K. Tanaka, C. Mann, H. Feldmann, M. Hochstrasser, R. Vierstra, S. Johnston, R. Hampton, J. Haber, J. Mccusker *et al.*: Unified nomenclature for subunits of the *Saccharomyces cerevisiae* proteasome regulatory particle. *Trends Biochem Sci* 23, 244-245 (1998)
87. Mykles, D.L.: Differential effects of bovine PA28 on six peptidase activities of the lobster muscle proteasome (multicatalytic proteinase). *Arch Biochem Biophys* 325, 77-81 (1996)
88. Ortiz-Navarrete, V., A. Seelig, M. Gernold, S. Frentzel, P.M. Kloetzel & G.J. Hammerling: Subunit of the '20S' proteasome (multicatalytic proteinase) encoded by the major histocompatibility complex. *Nature* 353, 662-668 (1991)
89. Glynn, R., S.H. Powis, S. Beck, A. Kelly, L.A. Kerr & J. Trowsdale: A proteasome-related gene between the two ABC transporter loci in the class II region of the human MHC. *Nature* 353, 357-360 (1991)
90. Martinez, C.K. & J.J. Monaco: Homology of proteasome subunits to a major histocompatibility complex-linked LMP gene. *Science* 353, 664-667 (1991)
91. Hisamatsu, H., N. Shimbara, Y. Saito, P. Kristensen, K.B. Hendil, T. Fujiwara, E. Takahashi, N. Tanahashi, T. Tamura, A. Ichihara *et al.*: Newly identified pair of proteasomal subunits regulated reciprocally by interferon-gamma. *J Exp Med* 183, 1807-1816 (1996)
92. Nandi, D., H. Jiang & J.J. Monaco: Identification of MECL-1 (LMP-10) as the third IFN-gamma-inducible proteasome subunit. *J Immunol* 156, 2361-2364 (1996)
93. Driscoll, J., M.G. Brown, D. Finley & J.J. Monaco: MHC-linked *LMP* gene products specifically alter peptidase activities of the proteasome. *Nature* 365, 262-264 (1993)
94. Gaczynska, M., K.L. Rock & A.L. Goldberg: Gamma-interferon and expression of MHC genes regulate peptide hydrolysis by proteasomes. *Nature* 365, 264-267 (1993)
95. Gaczynska, M., A.L. Goldberg, K. Tanaka, K. Hendil, K.L. Rock & K.B. Hendil: Proteasome subunits X and Y alter peptidase activities in opposite ways to the interferon-gamma-induced subunits LMP2 and LMP7. *J Biol Chem* 271, 17275-17280 (1996)
96. Orłowski, M., C. Cardozo, A.M. Eleuteri, R. Kohanski, C.M. Kam & J.C. Powers: Reactions of [<sup>14</sup>C]-3,4-dichloroisocoumarin with subunits of pituitary and spleen multicatalytic proteinase complexes (proteasomes). *Biochemistry* 36, 13946-13953 (1997)
97. Eleuteri, A.M., R.A. Kohanski, C. Cardozo & M. Orłowski: Bovine spleen multicatalytic proteinase complex (proteasome). Replacement of X, Y, and Z subunits by LMP7, LMP2, and MECL1 and changes in properties and specificity. *J Biol Chem* 272, 11824-11831 (1997)
98. Cardozo, C. & R.A. Kohanski: Altered properties of the branched chain amino acid-preferring activity contribute to increased cleavages after branched chain residues by the "Immunoproteasome". *J Biol Chem* 273, 16764-16770 (1998)
99. Fehling, H.J., W. Swat, C. Laplace, R. Kuhn, K. Rajewsky, U. Müller & H. von Boehmer: MHC class I expression in mice lacking the proteasome subunit LMP-7. *Science* 265, 1234-1237 (1994)
100. Van Kaer, L., P.G. Ashton-Rickardt, M. Eichelberger, M. Gaczynska, K. Nagashima, K.L. Rock, A.L. Goldberg, P.C. Doherty & S. Tonegawa: Altered peptidase and viral-specific T cell response in LMP2 mutant mice. *Immunity* 1, 533-541 (1994)
101. Cerundolo, V., A. Kelly, T. Elliott, J. Trowsdale & A. Townsend: Genes encoded in the major histocompatibility complex affecting the generation of peptides for TAP transport. *Eur J Immunol* 25, 554-562 (1995)
102. Sibille, C., K.G. Gould, K. Willard-Gallo, S. Thomson, A.J. Rivett, S. Powis, G.W. Butcher & P. De Baetselier: LMP2<sup>+</sup> proteasomes are required for the presentation of specific antigens to cytotoxic T lymphocytes. *Curr Biol* 5, 923-930 (1995)
103. Ustrell, V., C. Realini, G. Pratt & M. Rechsteiner: Human lymphoblast and erythrocyte multicatalytic proteases: differential peptidase activities and responses to the 11S regulator. *FEBS Lett* 376, 155-158 (1995)
104. Groettrup, M., A. Soza, M. Eggers, L. Kuehn, T.P. Dick, H. Schild, H.G. Rammensee, U.H. Koszinowski & P.M. Kloetzel: A role for the proteasome regulator PA28-alpha in antigen presentation. *Nature* 381, 166-168 (1996)
105. Dahlmann, B., F. Kopp, R. Hegerl, G. Pfeifer & W. Baumeister: The multicatalytic proteinase (prosome, proteasome): comparison of the eukaryotic and

## Proteasomes in the Archaea

- archaeobacterial enzyme. *Biomed Biochim Acta* 50, 465-469 (1991)
106. Wenzel, T., C. Eckerskorn, F. Lottspeich & W. Baumeister: Existence of a molecular ruler in proteasomes suggested by analysis of degradation products. *FEBS Lett* 349, 205-209 (1994)
107. Ehring, B., T.H. Meyer, C. Eckerskorn, F. Lottspeich & R. Tampe: Effects of major-histocompatibility-complex-encoded subunits on the peptidase and proteolytic activities of human 20S proteasomes. Cleavage of proteins and antigenic peptides. *Eur J Biochem* 235, 404-415 (1996)
108. Leibovitz, D., Y. Koch, F. Pitzer, M. Fridkin, A. Dantes, W. Baumeister & A. Amsterdam: Sequential degradation of the neuropeptide gonadotropin-releasing hormone by the 20 S granulosa cell proteasomes. *FEBS Lett* 346, 203-206 (1994)
109. Leibovitz, D., Y. Koch, M. Fridkin, F. Pitzer, P. Zwickl, A. Dantes, W. Baumeister & A. Amsterdam: Archaeobacterial and eukaryotic proteasome prefer different sites in cleaving gonadotrophin-releasing hormone. *J Biol Chem* 270, 11029-11032 (1995)
110. Brannigan, J.A., G. Dodson, H.J. Duggleby, P.C.E. Moody, J.L. Smith, D.R. Tomchick & A.G. Murzin: A protein catalytic framework with an N-terminal nucleophile is capable of self-activation. *Nature* 378, 416-419 (1995)
111. Duggleby, H.J., S.P. Tolley, C.P. Hill, E.J. Dodson, G. Dodson & P.C. Moody: Penicillin acylase has a single-amino-acid catalytic centre. *Nature* 373, 264-268 (1995)
112. Smith, J.L., E.J. Zaluzec, J.P. Wery, L. Niu, R.L. Switzer, H. Zalkin & Y. Satow: Structure of the allosteric regulatory enzyme of purine biosynthesis. *Science* 264, 1427-1433 (1994)
113. Oinonen, C., R. Tikkanen, J. Rouvinen & L. Peltonen: Three-dimensional structure of human lysosomal aspartylglucosaminidase. *Nat Struct Biol* 2, 1102-1108 (1995)
114. Seemüller, E., A. Lupas & W. Baumeister: Autocatalytic processing of the 20S proteasome. *Nature* 382, 468-470 (1996)
115. Fenteany, G., R.F. Standaert, W.S. Lane, S. Choi, E.J. Corey & S.L. Schreiber: Inhibition of proteasome activities and subunit-specific amino-terminal threonine modification by lactacystin. *Science* 268, 726-731 (1995)
116. Seemüller, E., A. Lupas, D. Stock, J. Löwe, R. Huber & W. Baumeister: Proteasome from *Thermoplasma acidophilum*: a threonine protease. *Science* 268, 579-582 (1995)
117. Seemüller, E., A. Lupas, F. Zühl, P. Zwickl & W. Baumeister: The proteasome from *Thermoplasma acidophilum* is neither a cysteine nor a serine protease. *FEBS Lett* 359, 173-178 (1995)
118. Mason, R.W.: Characterization of the active site of human multicatalytic proteinase. *Biochem J* 265, 479-484 (1990)
119. Djaballah, H., J.A. Harness, P.J. Savory & A.J. Rivett: Use of serine-protease inhibitors as probes for the different proteolytic activities of the rat liver multicatalytic proteinase complex. *Eur J Biochem* 209, 629-634 (1992)
120. Dick, L.R., A.A. Cruikshank, L. Grenier, F.D. Melandri, S.L. Nunes, R. Stein & R.L. Stein: Mechanistic studies on the inactivation of the proteasome by lactacystin: a central role for clasto-lactacystin beta-lactone. *J Biol Chem* 271, 7273-7276 (1996)
121. Heinemeyer, W., J.A. Kleinschmidt, J. Saidowsky, C. Escher & D.H. Wolf: Proteinase yscE, the yeast proteasome/multicatalytic-multifunctional proteinase: mutants unravel its function in stress induced proteolysis and uncover its necessity for cell survival. *EMBO J* 10, 555-562 (1991)
122. Hilt, W., C. Enenkel, A. Gruhler, T. Singer & D.H. Wolf: The *PRE4* gene codes for a subunit of the yeast proteasome necessary for peptidylglutamyl-peptide-hydrolyzing activity. Mutations link the proteasome to stress- and ubiquitin-dependent proteolysis. *J Biol Chem* 268, 3479-3486 (1993)
123. Enenkel, C., H. Lehmann, J. Kipper, R. Guckel, W. Hilt & D.H. Wolf: *PRE3*, highly homologous to the human major histocompatibility complex-linked *LMP2 (RING12)* gene, codes for a yeast proteasome subunit necessary for the peptidylglutamyl-peptide hydrolyzing activity. *FEBS Lett* 341, 193-196 (1994)
124. Gueckel, R., C. Enenkel, D.H. Wolf & W. Hilt: Mutations in the yeast proteasome beta-type subunit Pre3 uncover position-dependent effects on proteasomal peptidase activity and *in vivo* function. *J Biol Chem* 273, 19443-19452 (1998)
125. Arendt, C.S. & M. Hochstrasser: Eukaryotic 20S proteasome catalytic subunit propeptides prevent active site inactivation by N-terminal acetylation and promote particle assembly. *EMBO J* 18, 3575-3585 (1999)
126. Goldberg, A.L., T.N. Akopian, A.F. Kisselev, D.H. Lee & M. Rohrwild: New insights into the mechanisms and importance of the proteasome in intracellular protein degradation. *Biol Chem* 378, 131-140 (1997)
127. Dick, L.R., C.R. Moomaw, G.N. DeMartino & C.A. Slaughter: Degradation of oxidized insulin B chain by the multiproteinase complex macropain (proteasome). *Biochemistry* 30, 2725-2734 (1991)
128. Goldberg, A.L.: The mechanism and functions of ATP-dependent proteases in bacterial and animal cells. *Eur J Biochem* 203, 9-23 (1992)

## Proteasomes in the Archaea

129. Edmunds, T. & A.L. Goldberg: Role of ATP hydrolysis in the degradation of proteins by protease La from *Escherichia coli*. *J Cell Biochem* 32, 187-191 (1986)
130. Lin, L., G.N. DeMartino & W.C. Greene: Cotranslational biogenesis of NF-kappaB p50 by the 26S proteasome. *Cell* 92, 819-828 (1998)
131. Heusch, M., L. Lin, R. Geleziunas & W.C. Greene: The generation of NF-kappaB2 p52: mechanism and efficiency. *Oncogene* 18, 6201-6208 (1999)
132. Wang, R., B.T. Chait, I. Wolf, R.A. Kohanski & C. Cardozo: Lysozyme degradation by the bovine multicatalytic proteinase complex (proteasome): evidence for a nonprocessive mode of degradation. *Biochemistry* 38, 14573-14581 (1999)
133. Baumeister, W. & A. Lupas: The proteasome. *Curr Opin Struct Biol* 7, 273-278 (1997)
134. Stuart, D.I. & E.Y. Jones: Cutting complexity down to size. *Nature* 386, 437-438 (1997)
135. Kisselev, A.F., T.N. Akopian, V. Castillo & A.L. Goldberg: Proteasome active sites allosterically regulate each other, suggesting a cyclical bite-chew mechanism for protein breakdown. *Mol Cell* 4, 395-402 (1999)
136. Rohrwild, M., O. Coux, H.-C. Huang, R.P. Moerschell, S.J. Yoo, J.H. Seol, C.H. Chung, A.L. Goldberg & H.C. Huang: HslV-HslU: a novel ATP-dependent protease complex in *Escherichia coli* related to the eukaryotic proteasome. *Proc Natl Acad Sci USA* 93, 5808-5813 (1996)
137. Yoo, S.J., Y.K. Shim, I.S. Seong, J.H. Seol, M.S. Kang & C.H. Chung: Mutagenesis of two N-terminal Thr and five Ser residues in HslV, the proteolytic component of the ATP-dependent HslVU protease. *FEBS Lett* 412, 57-60 (1997)
138. Zwickl, P., F. Lottspeich, B. Dahlmann & W. Baumeister: Cloning and sequencing of the gene encoding the large (alpha-) subunit of the proteasome from *Thermoplasma acidophilum*. *FEBS Lett* 278, 217-221 (1991)
139. Zühl, F., T. Tamura, I. Dolenc, Z. Cejka, I. Nagy, R. De Mot, W. Baumeister & R. De Mot: Subunit topology of the *Rhodococcus* proteasome. *FEBS Lett* 400, 83-90 (1997)
140. Kawarabayasi, Y., Y. Hino, H. Horikawa, S. Yamazaki, Y. Haikawa, K. Jin-no, M. Takahashi, M. Sekine, S. Baba, A. Ankai *et al.*: Complete genome sequence of an aerobic hyper-thermophilic crenarchaeon, *Aeropyrum pernix* K1. *DNA Res* 6, 83-92 (1999)
141. Heilig, R.: *Pyrococcus abyssi* genome sequence: insights into archaeal chromosome structure and evolution, unpublished, Genbank accession AJ248283 to AJ248288.
142. Kawarabayasi, Y., M. Sawada, H. Horikawa, Y. Haidawa, Y. Hino, S. Yamamoto, M. Sekine, S. Baba, H. Kosugi, A. Hosoyama *et al.*: Complete sequence and gene organization of the genome of a hyper-thermophilic archaeobacterium, *Pyrococcus horikoshii* OT3. *DNA Res* 5, 147-155 (1998)
143. Clayton, R.A., O. White, K.A. Ketchum, & J.C. Venter: The first genome from the third domain of life. *Nature* 387, 459-462 (1997)
144. Hilt, W., W. Heinemeyer & D.H. Wolf: Studies on the yeast proteasome uncover its basic structural features and multiple *in vivo* functions. *Enzyme Protein* 47, 189-201 (1993)
145. Heinemeyer, W., N. Trondle, G. Albrecht & D.H. Wolf: *PRE5* and *PRE6*, the last missing genes encoding 20S proteasome subunits from yeast? Indication for a set of 14 different subunits in the eukaryotic proteasome core. *Biochemistry* 33, 12229-12237 (1994)
146. Murray, B.W., H. Sültmann & J. Klein: Analysis of a 26-kb region linked to the *Mhc* in zebrafish: genomic organization of the proteasome component beta/transporter associated with antigen processing-2 gene cluster and identification of five new proteasome beta subunit genes. *J Immunol* 163, 2657-2666 (1999)
147. Tanaka, K. & M. Kasahara: The MHC class I ligand-generating system: roles of immunoproteasomes and the interferon-gamma-inducible proteasome activator PA28. *Immunol Rev* 163, 161-176 (1998)
148. Brown, M.G., J. Driscoll & J.J. Monaco: MHC-linked low-molecular mass polypeptide subunits define distinct subsets of proteasomes. Implications for divergent function among distinct proteasome subsets. *J Immunol* 151, 1193-1204 (1993)
149. Früh, K., M. Gossen, K. Wang, H. Bujard, P.A. Peterson & Y. Yang: Displacement of housekeeping proteasome subunits by MHC-encoded LMPs: a newly discovered mechanism for modulating the multicatalytic proteinase complex. *EMBO J* 13, 3236-3244 (1994)
150. Martinez, C.K. & J.J. Monaco: Post-translational processing of a major histocompatibility complex-encoded proteasome subunit, LMP-2. *Mol Immunol* 30, 1177-1183 (1993)
151. Gerards, W.L., W.W. de Jong, W. Boelens & H. Bloemendal: Structure and assembly of the 20S proteasome. *Cell Mol Life Sci* 54, 253-262 (1998)
152. Kimura, Y., M. Takaoka, S. Tanaka, H. Sassa, K. Tanaka, B. Plevoda, F. Sherman & H. Hirano: N-alpha-acetylation and proteolytic activity of the yeast 20 S proteasome. *J Biol Chem* 275, 4635-4639 (2000)
153. Früh, K., Y. Yang, D. Arnold, J. Chambers, L. Wu, J.B. Waters, T. Spies & P.A. Peterson: Alternative exon usage and processing of the major histocompatibility complex-encoded proteasome subunits. *J Biol Chem* 267, 22131-22140 (1992)

## Proteasomes in the Archaea

154. Zühl,F., E. Seemüller, R. Golbik & W. Baumeister: Dissecting the assembly pathway of the 20S proteasome. *FEBS Lett* 418, 189-194 (1997)
155. Chen,P.& M. Hochstrasser: Autocatalytic subunit processing couples active site formation in the 20S proteasome to completion of assembly. *Cell* 86, 961-972 (1996)
156. Ditzel,L., R. Huber, K. Mann, W. Heinemeyer, D.H. Wolf & M. Groll: Conformational constraints for protein self-cleavage in the proteasome. *J Mol Biol* 279, 1187-1191 (1998)
157. Schmidtke,G., R. Kraft, S. Kostka, P. Henklein, C. Frommel, J. Löwe, R. Huber, P.M. Kloetzel & M. Schmidt: Analysis of mammalian 20S proteasome biogenesis: the maturation of beta-subunits is an ordered two-step mechanism involving autocatalysis. *EMBO J* 15, 6887-6898 (1996)
158. Groll,M., W. Heinemeyer, S. Jäger, T. Ullrich, M. Bochtler, D.H. Wolf & R. Huber: The catalytic sites of 20S proteasomes and their role in subunit maturation: a mutational and crystallographic study. *Proc Natl Acad Sci USA* 96, 10976-10983 (1999)
159. Nussbaum,A.K., T.P. Dick, W. Keilholz, M. Schirle, S. Stevanovic, K. Dietz, W. Heinemeyer, M. Groll, D.H. Wolf, R. Huber *et al.*: Cleavage motifs of the yeast 20S proteasome beta subunits deduced from digests of enolase 1. *Proc Natl Acad Sci USA* 95, 12504-12509 (1998)
160. Heinemeyer,W., M. Fischer, T. Krimmer, U. Stachon & D.H. Wolf: The active sites of the eukaryotic 20S proteasome and their involvement in subunit precursor processing. *J Biol Chem* 272, 25200-25209 (1997)
161. Jäger,S., M. Groll, R. Huber, D.H. Wolf & W. Heinemeyer: Proteasome beta-type subunits: unequal roles of propeptides in core particle maturation and a hierarchy of active site function. *J Mol Biol* 291, 997-1013 (1999)
162. Braun,P.& J. Tommassen: Function of bacterial propeptides. *Trends Microbiol* 6, 6-8 (1998)
163. Huang,H.-C.& A.L. Goldberg: Proteolytic activity of the ATP-dependent protease HslVU can be uncoupled from ATP hydrolysis. *J Biol Chem* 272, 21364-21372 (1997)
164. Yoo,S.J., J.H. Seol, D.H. Shin, M. Rohrwild, M.-S. Kang, K. Tanaka, A.L. Goldberg, C.H. Chung & M.S. Kang: Purification and characterization of the heat shock proteins HslV and HslU that form a new ATP-dependent protease in *Escherichia coli*. *J Biol Chem* 271, 14035-14040 (1996)
165. Bogyo,M., J.S. McMaster, M. Gaczynska, D. Tortorella, A.L. Goldberg & H. Ploegh: Covalent modification of the active site threonine of proteasomal beta subunits and the *Escherichia coli* homolog HslV by a new class of inhibitors. *Proc Natl Acad Sci USA* 94, 6629-6634 (1997)
166. Chen,P.& M. Hochstrasser: Biogenesis, structure, and function of the yeast 20S proteasome. *EMBO J* 14, 2620-2630 (1995)
167. Zwickl,P., J. Kleinz & W. Baumeister: Critical elements in proteasome assembly. *Nat Struct Biol* 1, 765-770 (1994)
168. Gerards,W.L., J. Enzlin, M. Haner, I.L. Hendriks, U. Aebi, H. Bloemendal & W. Boelens: The human alpha-type proteasomal subunit HsC8 forms a double ringlike structure, but does not assemble into proteasome-like particles with the beta-type subunits HsDelta or HsBPROS26. *J Biol Chem* 272, 10080-10086 (1997)
169. Yao,Y., C.R. Toth, L. Huang, M.L. Wong, P. Dias, A.L. Burlingame, P. Coffino & C.C. Wang: Alpha5 subunit in *Trypanosoma brucei* proteasome can self-assemble to form a cylinder of four stacked heptamer rings. *Biochem J* 344, 349-358 (1999)
170. Gerards,W.L., W.W. de Jong, H. Bloemendal & W. Boelens: The human proteasomal subunit HsC8 induces ring formation of other alpha-type subunits. *J Mol Biol* 275, 113-121 (1998)
171. Seelig,A., G. Multhaup, B. Pesold-Hurt, K. Beyreuther & P.M. Kloetzel: *Drosophila* proteasome Dm25 subunit substitutes the mouse MC3 subunit in hybrid proteasomes. The N-terminal domain is essential for subunit incorporation. *J Biol Chem* 268, 25561-25567 (1993)
172. Frentzel,S., B. Pesold-Hurt, A. Seelig, P.-M. Kloetzel & P.M. Kloetzel: 20 S proteasomes are assembled *via* distinct precursor complexes. Processing of LMP2 and LMP7 propeptides take place in 13-16 S preproteasome complexes. *J Mol Biol* 236, 975-981 (1994)
173. Schmidtke,G., M. Schmidt, P.-M. Kloetzel & P.M. Kloetzel: Maturation of mammalian 20S proteasome: purification and characterization of 13S and 16S proteasome precursor complexes. *J Mol Biol* 268, 95-106 (1997)
174. Nandi,D., E. Woodward, D.B. Ginsburg & J.J. Monaco: Intermediates in the formation of mouse 20S proteasomes: implications for the assembly of precursor beta subunits. *EMBO J* 16, 5363-5375 (1997)
175. Ramos,P.C., J. Hockendorff, E.S. Johnson, A. Varshavsky & R.J. Dohmen: Ump1p is required for proper maturation of the 20S proteasome and becomes its substrate upon completion of the assembly. *Cell* 92, 489-499 (1998)
176. Maurizi,M.R.: Proteasome assembly: biting the hand. *Curr Biol* 8, R453-6 (1998)
177. Schmidt,M., G. Schmidtke & P.M. Kloetzel: Structure and structure formation of the 20S proteasome. *Mol Biol Rep* 24, 103-112 (1997)
178. Beyer,A.: Sequence analysis of the AAA protein family. *Protein Sci* 6, 2043-2058 (1997)



## Proteasomes in the Archaea

179. Confalonieri, F. & M. Duguet: A 200-amino acid ATPase module in search of a basic function. *BioEssays* 17, 639-650 (1995)
180. Neuwald, A.F., L. Aravind, J.L. Spouge & E.V. Koonin: AAA+: A class of chaperone-like ATPases associated with the assembly, operation, and disassembly of protein complexes. *Genome Res* 9, 27-43 (1999)
181. Patel, S. & M. Latterich: The AAA team: related ATPases with diverse functions. *Trends Cell Biol* 8, 65-71 (1998)
182. Schirmer, E.C., J.R. Glover, M.A. Singer & S. Lindquist: HSP100/Clp proteins: a common mechanism explains diverse functions. *Trends Biochem Sci* 21, 289-296 (1996)
183. Swaffield, J.C. & M.D. Purugganan: The evolution of the conserved ATPase domain (CAD): reconstructing the history of an ancient protein module. *J Mol Evol* 45, 549-563 (1997)
184. Saraste, M., P.R. Sibbald & A. Wittinghofer: The P-loop--a common motif in ATP- and GTP-binding proteins. *Trends Biochem Sci* 15, 430-434 (1990)
185. Walker, J.E., M. Saraste, M.J. Runswick & N.J. Gay: Distantly related sequences in the alpha- and beta-subunits of ATP synthase, myosin, kinases and other ATP-requiring enzymes and a common nucleotide binding fold. *EMBO J* 1, 945-951 (1982)
186. Karata, K., T. Inagawa, A.J. Wilkinson, T. Tatsuta & T. Ogura: Dissecting the role of a conserved motif (the second region of homology) in the AAA family of ATPases. Site-directed mutagenesis of the ATP-dependent protease FtsH. *J Biol Chem* 274, 26225-26232 (1999)
187. Smith, C.K., T.A. Baker & R.T. Sauer: Lon and Clp family proteases and chaperones share homologous substrate-recognition domains. *Proc Natl Acad Sci USA* 96, 6678-6682 (1999)
188. Levchenko, I., C.K. Smith, N.P. Walsh, R.T. Sauer & T.A. Baker: PDZ-like domains mediate binding specificity in the Clp/Hsp100 family of chaperones and protease regulatory subunits. *Cell* 91, 939-947 (1997)
189. Lucero, H.A., E.W. Chojnicki, S. Mandiyan, H. Nelson & N. Nelson: Cloning and expression of a yeast gene encoding a protein with ATPase activity and high identity to the subunit 4 of the human 26 S protease. *J Biol Chem* 270, 9178-9184 (1995)
190. Leonhard, K., A. Stiegler, W. Neupert & T. Langer: Chaperone-like activity of the AAA domain of the yeast Yme1 AAA protease. *Nature* 398, 348-351 (1999)
191. Richmond, C., C. Gorbea & M. Rechsteiner: Specific interactions between ATPase subunits of the 26 S protease. *J Biol Chem* 272, 13403-13411 (1997)
192. Seol, J.H., S.J. Yoo, M.S. Kang, D.B. Ha & C.H. Chung: The 65-kDa protein derived from the internal translational start site of the *clpA* gene blocks autodegradation of ClpA by the ATP-dependent protease Ti in *Escherichia coli*. *FEBS Lett* 377, 41-43 (1995)
193. Guenther, B., R. Onrust, A. Sali, M. O'Donnell & J. Kuriyan: Crystal structure of the delta' subunit of the clamp-loader complex of *E. coli* DNA polymerase III. *Cell* 91, 335-345 (1997)
194. Lenzen, C.U., D. Steinmann, S.W. Whiteheart & W.I. Weiss: Crystal structure of the hexamerization domain of N-ethylmaleimide-sensitive fusion protein. *Cell* 94, 525-536 (1998)
195. Yu, R.C., P.I. Hanson, R. Jahn & A.T. Brunger: Structure of the ATP-dependent oligomerization domain of N-ethylmaleimide sensitive factor complexed with ATP. *Nat Struct Biol* 5, 803-811 (1998)
196. Walz, J., A. Erdmann, M. Kania, D. Typke, A.J. Koster & W. Baumeister: 26S proteasome structure revealed by three-dimensional electron microscopy. *J Struct Biol* 121, 19-29 (1998)
197. Beuron, F., M.R. Maurizi, D.M. Belnap, E. Kocsis, F.P. Booy, M. Kessel & A.C. Steven: At sixes and sevens: characterization of the symmetry mismatch of the ClpAP chaperone-assisted protease. *J Struct Biol* 123, 248-259 (1998)
198. Rockel, B., J. Walz, R. Hegerl, J. Peters, D. Typke & W. Baumeister: Structure of VAT, a CDC48/p97 ATPase homologue from the archaeon *Thermoplasma acidophilum* as studied by electron tomography. *FEBS Lett* 451, 27-32 (1999)
199. Ahmadian, M.R., P. Stege, K. Scheffzek & A. Wittinghofer: Confirmation of the arginine-finger hypothesis for the GAP-stimulated GTP-hydrolysis reaction of Ras. *Nat Struct Biol* 4, 686-689 (1997)
200. Chu-Ping, M., C.A. Slaughter & G.N. DeMartino: Purification and characterization of a protein inhibitor of the 20S proteasome (macropain). *Biochim Biophys Acta* 1119, 303-311 (1992)
201. Dubiel, W., K. Ferrell & M. Rechsteiner: Subunits of the regulatory complex of the 26S protease. *Mol Biol Rep* 21, 27-34 (1995)
202. Rechsteiner, M., L. Hoffman & W. Dubiel: The multicatalytic and 26S proteases. *J Biol Chem* 268, 6065-6068 (1993)
203. Tanahashi, N., H. Kawahara, Y. Murakami & K. Tanaka: The proteasome-dependent proteolytic system. *Mol Biol Rep* 26, 3-9 (1999)
204. Hoffman, L., G. Pratt & M. Rechsteiner: Multiple forms of the 20 S multicatalytic and the 26 S ubiquitin/ATP-dependent proteases from rabbit reticulocyte lysate. *J Biol Chem* 267, 22362-22368 (1992)

## Proteasomes in the Archaea

205. Glickman, M.H., D.M. Rubin, O. Coux, I. Wefes, G. Pfeifer, Z. Cjeka, W. Baumeister, V.A. Fried & D. Finley: A subcomplex of the proteasome regulatory particle required for ubiquitin-conjugate degradation and related to the COP9-signalosome and eIF3. *Cell* 94, 615-623 (1998)
206. Wickner, S., S. Gottesman, D. Skowyra, J. Hoskins, K. McKenney & M.R. Maurizi: A molecular chaperone, ClpA, functions like DnaK and DnaJ. *Proc Natl Acad Sci USA* 91, 12218-12222 (1994)
207. Braun, B.C., M. Glickman, R. Kraft, B. Dahlmann, P.M. Kloetzel, D. Finley & M. Schmidt: The base of the proteasome regulatory particle exhibits chaperone-like activity. *Nat Cell Biol* 1, 221-226 (1999)
208. Pak, M., J.R. Hoskins, S.K. Singh, M.R. Maurizi & S. Wickner: Concurrent chaperone and protease activities of ClpAP and the requirement for the N-terminal ClpA ATP binding site for chaperone activity. *J Biol Chem* 274, 19316-19322 (1999)
209. Strickland, E., K. Hakala, P.J. Thomas & G.N. DeMartino: Recognition of misfolding proteins by PA700, 215. Hershko, A. & A. Ciechanover: The ubiquitin system. *Annu Rev Biochem* 67, 425-480 (1998)
216. Xie, Y. & A. Varshavsky: Physical association of ubiquitin ligases and the 26S proteasome. *Proc Natl Acad Sci USA* 97, 2497-2502 (2000)
217. Rechsteiner, M. & S.W. Rogers: PEST sequences and regulation by proteolysis. *Trends Biochem Sci* 21, 267-271 (1996)
218. Varshavsky, A.: The N-end rule pathway of protein degradation. *Genes Cells* 2, 13-28 (1997)
219. Beal, R.E., D. Toscano-Cantaffa, P. Young, M. Rechsteiner & C.M. Pickart: The hydrophobic effect contributes to polyubiquitin chain recognition. *Biochemistry* 37, 2925-2934 (1998)
220. Fuchs, S.Y., V.A. Fried & Z. Ronai: Stress-activated kinases regulate protein stability. *Oncogene* 17, 1483-1490 (1998)
221. Lin, L. & S. Ghosh: A glycine-rich region in NF-kappaB p105 functions as a processing signal for the generation of the p50 subunit. *Mol Cell Biol* 16, 2248-2254 (1996)
222. Glotzer, M., A.W. Murray & M.W. Kirschner: Cyclin is degraded by the ubiquitin pathway. *Nature* 349, 132-138 (1991)
223. Luca, F.C., E.K. Shibuya, C.E. Dohrmann & J.V. Ruderman: Both cyclin A delta60 and B delta97 are stable and arrest cells in M-phase, but only cyclin B delta97 turns on cyclin destruction. *EMBO J* 10, 4311-4320 (1991)
224. Su, K., M.D. Roos, X. Yang, I. Han, A.J. Paterson & J.E. Kudlow: An N-terminal region of Sp1 targets its the regulatory subcomplex of the 26 S proteasome. *J Biol Chem* 275, 5565-5572 (2000)
210. Wojtkowiak, D., C. Georgopoulos & M. Zylicz: Isolation and characterization of ClpX, a new ATP-dependent specificity component of the Clp protease of *Escherichia coli*. *J Biol Chem* 268, 22609-22617 (1993)
211. Mhammedi-Alaoui, A., M. Pato, M.J. Gama & A. Toussaint: A new component of bacteriophage Mu replicative transposition machinery: the *Escherichia coli* ClpX protein. *Mol Microbiol* 11, 1109-1116 (1994)
212. Hoskins, J.R., M. Pak, M.R. Maurizi & S. Wickner: The role of the ClpA chaperone in proteolysis by ClpAP. *Proc Natl Acad Sci USA* 95, 12135-12140 (1998)
213. Hartl, F.U.: Molecular chaperones in cellular protein folding. *Nature* 381, 571-579 (1996)
214. Russell, S.J., S.H. Reed, W. Huang, E.C. Friedberg & S.A. Johnston: The 19S regulatory complex of the proteasome functions independently of proteolysis in nucleotide excision repair. *Mol Cell* 3, 687-695 (1999)
215. Hershko, A. & A. Ciechanover: The ubiquitin system. *Annu Rev Biochem* 67, 425-480 (1998)
225. Chung, D.H., K. Ohashi, M. Watanabe, N. Miyasaka & S. Hirose: Mannose trimming targets mutant alpha<sub>2</sub>-plasmin inhibitor for degradation by the proteasome. *J Biol Chem* 275, 4981-4987 (2000)
226. Hochstrasser, M.: There's the rub: a novel ubiquitin-like modification linked to cell cycle regulation. *Genes Dev* 12, 901-907 (1998)
227. D'Andrea, A. & D. Pellman: Deubiquitinating enzymes: a new class of biological regulators. *Crit Rev Biochem Mol Biol* 33, 337-352 (1998)
228. Liakopoulos, D., G. Doenges, K. Matuschewski & S. Jentsch: A novel protein modification pathway related to the ubiquitin system. *EMBO J* 17, 2208-2214 (1998)
229. Pickart, C.M.: Targeting of substrates to the 26S proteasome. *FASEB J* 11, 1055-1066 (1997)
230. Hayashi, S. & Y. Murakami: Rapid and regulated degradation of ornithine decarboxylase. *Biochem J* 306, 1-10 (1995)
231. Hayashi, S., Y. Murakami & S. Matsufuji: Ornithine decarboxylase antizyme: a novel type of regulatory protein. *Trends Biochem Sci* 21, 27-30 (1996)
232. Li, X. & P. Coffino: Degradation of ornithine decarboxylase: exposure of the C-terminal target by a polyamine-inducible inhibitory protein. *Mol Cell Biol* 13, 2377-2383 (1993)
233. Murakami, Y., S. Matsufuji, T. Kameji, S.-I. Hayashi, K. Igarashi, T. Tamura, K. Tanaka & A. Ichihara: Ornithine decarboxylase is degraded by the 26S

## Structure and function of proteasomes

- proteasome without ubiquitination. *Nature* 360, 597-599 (1992)
234. Jariel-Encontre, I., M. Pariat, F. Martin, S. Carillo, C. Salvat & M. Piechaczyk: Ubiquitylation is not an absolute requirement for degradation of c-Jun protein by the 26S proteasome. *J Biol Chem* 270, 11623-11627 (1995)
235. Krappmann, D., F.G. Wulczyn & C. Scheidereit: Different mechanisms control signal-induced degradation and basal turnover of the NF-kappaB inhibitor I kappa B alpha *in vivo*. *EMBO J* 15, 6716-6726 (1996)
236. Treier, M., L.M. Staszewski & D. Bohmann: Ubiquitin-dependent c-Jun degradation *in vivo* is mediated by the delta domain. *Cell* 78, 787-798 (1994)
237. Rousset, R., C. Desbois, F. Bantignies & P. Jalinot: Effects on NF-kappa B1/p105 processing of the interaction between the HTLV-I transactivator Tax and the proteasome. *Nature* 381, 328-331 (1996)
238. Fischer, M., L. Runkel & H. Schaller: HBx protein of hepatitis B virus interacts with the C-terminal portion of a novel human proteasome alpha-subunit. *Virus Genes* 10, 99-102 (1995)
239. Boldin, M.P., I.L. Mett & D. Wallach: A protein related to a proteasomal subunit binds to the intracellular domain of the p55 TNF receptor upstream to its 'death domain'. *FEBS Lett* 367, 39-44 (1995)
240. Dawson, S., R. Hastings, K. Takayanagi, S. Reynolds, P. Low, M. Billett & R.J. Mayer: The 26S-proteasome: regulation and substrate recognition. *Mol Biol Rep* 24, 39-44 (1997)
241. Hastings, R., G. Walker, I. Eyheralde, S. Dawson, M. Billett & R.J. Mayer: Activator complexes containing the proteasomal regulatory ATPases S10b (SUG2) and S6 (TBP1) in different tissues and organisms. *Mol Biol Rep* 26, 35-38 (1999)
242. Parsell, D.A. & R.T. Sauer: Induction of a heat shock-like response by unfolded protein in *Escherichia coli*: dependence on protein level not protein degradation. *Genes Dev* 3, 1226-1232 (1989)
243. Parsell, D.A. & R.T. Sauer: The structural stability of a protein is an important determinant of its proteolytic susceptibility in *Escherichia coli*. *J Biol Chem* 264, 7590-7595 (1989)
244. Gonciarz-Swiatek, M., A. Wawrzynow, S.J. Um, B.A. Learn, R. McMacken, W.L. Kelley, C. Georgopoulos, O. Sliemers & M. Zylicz: Recognition, targeting, and hydrolysis of the lambda O replication protein by the ClpP/ClpX protease. *J Biol Chem* 274, 13999-14005 (1999)
245. Gottesman, S., E. Roche, Y. Zhou & R.T. Sauer: The ClpXP and ClpAP proteases degrade proteins with carboxy-terminal peptide tails added by the SsrA-tagging system. *Genes Dev* 12, 1338-1347 (1998)
246. Herman, C., D. Thevenet, P. Bouloc, G.C. Walker & R. D'Ari: Degradation of carboxy-terminal-tagged cytoplasmic proteins by the *Escherichia coli* protease HflB (FtsH). *Genes Dev* 12, 1348-1355 (1998)
247. Laachouch, J.E., L. Desmet, V. Geuskens, R. Grimaud & A. Toussiant: Bacteriophage Mu repressor as a target for the *Escherichia coli* ATP-dependent Clp protease. *EMBO J* 15, 437-444 (1996)
248. Levchenko, I., T.A. Baker & L. Luo: Disassembly of the Mu transposase tetramer by the ClpX chaperone. *Genes Dev* 9, 2399-2408 (1995)
249. Levchenko, I., M. Yamauchi & T.A. Baker: ClpX and MuB interact with overlapping regions of Mu transposase: implications for control of the transposition pathway. *Genes Dev* 11, 1561-1572 (1997)
250. Parsell, D.A., K.R. Silber & R.T. Sauer: Carboxy-terminal determinants of intracellular protein degradation. *Genes Dev* 4, 277-286 (1990)
251. Keiler, K.C., P.R.H. Waller, R.T. Sauer & P.R. Waller: Role of a peptide tagging system in degradation of proteins synthesized from damaged messenger RNA. *Science* 271, 990-993 (1996)
252. Roche, E.D. & R.T. Sauer: SsrA-mediated peptide tagging caused by rare codons and tRNA scarcity. *EMBO J* 18, 4579-4589 (1999)
253. Becker, G., E. Klauck & R. Hengge-Aronis: Regulation of RpoS proteolysis in *Escherichia coli*: the response regulator RssB is a recognition factor that interacts with the turnover element in RpoS. *Proc Natl Acad Sci USA* 96, 6439-6444 (1999)
254. Klenk, H.-P., R.A. Clayton, J.F. Tomb, O. White, K.E. Nelson, K.A. Ketchum, R.J. Dodson, M. Gwinn, E.K. Hickey, J.D. Peterson *et al.*: The complete genome sequence of the hyperthermophilic, sulphate-reducing archaeon *Archaeoglobus fulgidus*. *Nature* 390, 364-370 (1997)
255. Smith, D.R., L.A. Doucette-Stamm, C. Deloughery, H. Lee, J. Dubois, T. Aldredge, R. Bashirzadeh, D. Blakely, R. Cook, K. Gilbert *et al.*: Complete genome sequence of *Methanobacterium thermoautotrophicum* Delta H: functional analysis and comparative genomics. *J Bacteriol* 179, 7135-7155 (1997)
256. Bult, C.J., O. White, G.J. Olsen, L. Zhou, D. Fleischmann, G.G. Sutton, J.A. Blake, M. FitzGerald, R.A. Clayton, J.D. Gocayne *et al.*: Complete genome sequence of the methanogenic archaeon, *Methanococcus jannaschii*. *Science* 273, 1058-1073 (1996)
257. Sensen, C.W., R.L. Charlebois, C. Chow, I.G. Clausen, B. Curtis, W.F. Doolittle, M. Duguet, G. Erauso, T. Gaasterland, R.A. Garrett *et al.*: Completing the sequence of the *Sulfolobus solfataricus* P2 genome. *Extremophiles* 2, 305-312 (1998)

## Structure and function of proteasomes

258. Barns, S.M., C.F. Delwiche, J.D. Palmer & N.R. Pace: Perspectives on archaeal diversity, thermophily and monophyly from environmental rRNA sequences. *Proc Natl Acad Sci USA* 93, 9188-9193 (1996)
259. Li, Z., S. Pandit & M.P. Deutscher: 3' exoribonucleolytic trimming is a common feature of the maturation of small, stable RNAs in *Escherichia coli*. *Proc Natl Acad Sci USA* 95, 2856-2861 (1998)
260. Schmid, H.P., O. Akhayat, C.M. de Sa, F. Puvion, K. Koehler & K. Scherrer: The prosome: an ubiquitous morphologically distinct RNP particle associated with repressed mRNPs and containing specific ScRNA and a characteristic set of proteins. *EMBO J* 3, 29-34 (1984)
261. Castano, J.G., R. Ornberg, J.G. Koster, J.A. Tobian & M. Zasloff: Eukaryotic pre-tRNA 5' processing nuclease: copurification with a complex cylindrical particle. *Cell* 46, 377-385 (1986)
262. Shelton, E., E.L. Kuff, E.S. Maxwell & J.T. Harrington: Cytoplasmic particles and aminoacyl transferase I activity. *J Cell Biol* 45, 1-8 (1970)
263. Arrigo, A.-P., K. Tanaka, A.L. Goldberg & W.J. Welch: Identity of the 19S 'prosome' particle with the large multifunctional protease complex of mammalian cells (the proteasome). *Nature* 331, 192-194 (1988)
264. Falkenburg, P.E., C. Haass, P.M. Kloetzel, B. Niedel, F. Kopp, L. Kuehn & B. Dahlmann: *Drosophila* small cytoplasmic 19S ribonucleoprotein is homologous to the rat multicatalytic proteinase. *Nature* 331, 190-192 (1988)
265. Ruggero, D., A. Ciammaruconi & P. Londei: The chaperonin of the archaeon *Sulfolobus solfataricus* is an RNA-binding protein that participates in ribosomal RNA processing. *EMBO J* 17, 3471-3477 (1998)
266. Pamnani, V., B. Haas, G. Puhler, H.L. Sanger & W. Baumeister: Proteasome-associated RNAs are non-specific. *Eur J Biochem* 225, 511-519 (1994)
267. Ogura, T., T. Tomoyasu, T. Yuki, S. Morimura, K.J. Begg, W.D. Donachie, H. Mori, H. Niki & S. Hiraga: Structure and function of the *ftsH* gene in *Escherichia coli*. *Res Microbiol* 142, 279-282 (1991)
268. Stahlberg, H., E. Kutejova, K. Suda, B. Wolpensinger, A. Lustig, G. Schatz, A. Engel & C.K. Suzuki: Mitochondrial Lon of *Saccharomyces cerevisiae* is a ring-shaped protease with seven flexible subunits. *Proc Natl Acad Sci USA* 96, 6787-6790 (1999)
269. Amerik, A.Y., V.K. Antonov, A.E. Gorbalenya, S.A. Kotova, T.V. Rotanova & E.V. Shimbarevich: Site-directed mutagenesis of La protease. A catalytically active serine residue. *FEBS Lett* 287, 211-214 (1991)
270. Fischer, H. & R. Glockshuber: ATP hydrolysis is not stoichiometrically linked with proteolysis in the ATP-dependent protease La from *Escherichia coli*. *J Biol Chem* 268, 22502-22507 (1993)
271. Rasulova, F.S., N.I. Dergousova, N.N. Starkova, E.E. Melnikov, L.D. Rumsh, L.M. Ginodman & T.V. Rotanova: The isolated proteolytic domain of *Escherichia coli* ATP-dependent protease Lon exhibits the peptidase activity. *FEBS Lett* 432, 179-181 (1998)
272. Starkova, N.N., E.P. Koroleva, L.D. Rumsh, L.M. Ginodman & T.V. Rotanova: Mutations in the proteolytic domain of *Escherichia coli* protease Lon impair the ATPase activity of the enzyme. *FEBS Lett* 422, 218-220 (1998)
273. Pallen, M.J. & B.W. Wren: The HtrA family of serine proteases. *Mol Microbiol* 26, 209-221 (1997)
274. Skórko-Glonek, J., A. Wawrzynow, K. Krzewski, K. Kurpierz & B. Lipinska: Site-directed mutagenesis of the HtrA (DegP) serine protease, whose proteolytic activity is indispensable for *Escherichia coli* survival at elevated temperatures. *Gene* 163, 47-52 (1995)
275. Seol, J.H., S.K. Woo, E.M. Jung, S.J. Yoo, C.S. Lee, K.J. Kim, K. Tanaka, A. Ichihara, D.B. Ha & C.H. Chung: Protease Do is essential for survival of *Escherichia coli* at high temperatures: its identity with the *htrA* gene product. *Biochem Biophys Res Commun* 176, 730-736 (1991)
276. Skórko-Glonek, J., D. Zurawa, E. Kuczwarra, M. Wozniak, Z. Wypych & B. Lipinska: The *Escherichia coli* heat shock protease HtrA participates in defense against oxidative stress. *Mol Gen Genet* 262, 342-350 (1999)
277. Kim, K.I., S.C. Park, S.H. Kang, G.W. Cheong & C.H. Chung: Selective degradation of unfolded proteins by the self-compartmentalizing HtrA protease, a periplasmic heat shock protein in *Escherichia coli*. *J Mol Biol* 294, 1363-1374 (1999)
278. Hilt, W. & D.H. Wolf: Stress-induced proteolysis in yeast. *Mol Microbiol* 6, 2437-2442 (1992)
279. Ciechanover, A., D. Finley & A. Varshavsky: Ubiquitin dependence of selective protein degradation demonstrated in the mammalian cell cycle mutant ts85. *Cell* 37, 57-66 (1984)
280. Finley, D., A. Ciechanover & A. Varshavsky: Thermolability of ubiquitin-activating enzyme from the mammalian cell cycle mutant ts85. *Cell* 37, 43-55 (1984)
281. Rose, I.A. & J.V. Warms: A specific endpoint assay for ubiquitin. *Proc Natl Acad Sci USA* 84, 1477-1481 (1987)
282. Finley, D., E. Özkaynak & A. Varshavsky: The yeast polyubiquitin gene is essential for resistance to high temperatures, starvation, and other stresses. *Cell* 48, 1035-1046 (1987)
283. Jentsch, S., W. Seufert & H.-P. Hauser: Genetic analysis of the ubiquitin system. *Biochim Biophys Acta* 1089, 127-139 (1991)

## Structure and function of proteasomes

284. Watt,R.& P.W. Piper: *UBI4*, the polyubiquitin gene of *Saccharomyces cerevisiae*, is a heat shock gene that is also subject to catabolite derepression control. *Mol Gen Genet* 253, 439-447 (1997)
285. Treger,J.M., K.A. Heichman & K. McEntee: Expression of the yeast *UBI4* gene increases in response to DNA-damaging agents and in meiosis. *Mol Cell Biol* 8, 1132-1136 (1988)
286. Müller-Taubenberger,A., J. Hagmann, A. Noegel & G. Gerisch: Ubiquitin gene expression in *Dictyostelium* is induced by heat and cold shock, cadmium, and inhibitors of protein synthesis. *J Cell Sci* 90 ( Pt 1), 51-58 (1988)
287. Simon,J.R., J.M. Treger & K. McEntee: Multiple independent regulatory pathways control *UBI4* expression after heat shock in *Saccharomyces cerevisiae*. *Mol Microbiol* 31, 823-832 (1999)
288. Papa,F.R.& M. Hochstrasser: The yeast *DOA4* gene encodes a deubiquitinating enzyme related to a product of the human tre-2 oncogene. *Nature* 366, 313-319 (1993)
289. Madura,K., S. Prakash & L. Prakash: Expression of the *Saccharomyces cerevisiae* DNA repair gene *RAD6* that encodes a ubiquitin conjugating enzyme, increases in response to DNA damage and in meiosis but remains constant during the mitotic cell cycle. *Nucleic Acids Res* 18, 771-778 (1990)
290. Seufert,W.& S. Jentsch: Ubiquitin-conjugating enzymes *UBC4* and *UBC5* mediate selective degradation of short-lived and abnormal proteins. *EMBO J* 9, 543-550 (1990)
291. Seufert,W., J.P. McGrath & S. Jentsch: *UBC1* encodes a novel member of an essential subfamily of yeast ubiquitin-conjugating enzymes involved in protein degradation. *EMBO J* 9, 4535-4541 (1990)
292. Jentsch,S., J.P. McGrath & A. Varshavsky: The yeast DNA repair gene *RAD6* encodes a ubiquitin-conjugating enzyme. *Nature* 329, 131-134 (1987)
293. Fischer,M., W. Hilt, B. Richter-Ruoff, H. Gonen, A. Ciechanover & D.H. Wolf: The 26S proteasome of the yeast *Saccharomyces cerevisiae*. *FEBS Lett* 355, 69-75 (1994)
294. Ogiso,Y., A. Tomida, H.D. Kim & T. Tsuruo: Glucose starvation and hypoxia induce nuclear accumulation of proteasome in cancer cells. *Biochem Biophys Res Commun* 258, 448-452 (1999)
295. Wang,H.R., M. Kania, W. Baumeister & P.M. Nederlof: Import of human and *Thermoplasma* 20S proteasomes into nuclei of HeLa cells requires functional NLS sequences. *Eur J Cell Biol* 73, 105-113 (1997)
296. Lee,D.H.& A.L. Goldberg: Proteasome inhibitors cause induction of heat shock proteins and trehalose, which together confer thermotolerance in *Saccharomyces cerevisiae*. *Mol Cell Biol* 18, 30-38 (1998)
297. Meriin,A.B., V.L. Gabai, J. Yaglom, V.I. Shifrin & M.Y. Sherman: Proteasome inhibitors activate stress kinases and induce hsp72. Diverse effects on apoptosis. *J Biol Chem* 273, 6373-6379 (1998)
298. Kawazoe,Y., A. Nakai, M. Tanabe & K. Nagata: Proteasome inhibition leads to the activation of all members of the heat-shock-factor family. *Eur J Biochem* 255, 356-362 (1998)
299. Wagner,B.J.& J.W. Margolis: Age-dependent association of isolated bovine lens multicatalytic proteinase complex (proteasome) with heat-shock protein 90, an endogenous inhibitor. *Arch Biochem Biophys* 323, 455-462 (1995)
300. Conconi,M., I. Petropoulos, I. Emod, E. Turlin, F. Biville & B. Friguet: Protection from oxidative inactivation of the 20S proteasome by heat-shock protein 90. *Biochem J* 333, 407-415 (1998)
301. Wagner,B.J.& J.W. Margolis: Thermal stability and activation of bovine lens multicatalytic proteinase complex (proteasome). *Arch Biochem Biophys* 307, 146-152 (1993)
302. Ohba,M.: A 70-kDa heat shock cognate protein suppresses the defects caused by a proteasome mutation in *Saccharomyces cerevisiae*. *FEBS Lett* 351, 263-266 (1994)
303. Savel'ev,A.S., L.W. Novikova, I.E. Kovaleva, V.N. Luzikov, W. Neupert & T. Langer: ATP-dependent proteolysis in mitochondria. m-AAA protease and PIM1 protease exert overlapping substrate specificities and cooperate with the mtHsp70 system. *J Biol Chem* 273, 20596-20602 (1998)
304. Cooper,K.F., M.J. Mallory & R. Strich: Oxidative stress-induced destruction of the yeast C-type cyclin Ume3p requires phosphatidylinositol-specific phospholipase C and the 26S proteasome. *Mol Cell Biol* 19, 3338-3348 (1999)
305. Sherman,M.Y.& A.L. Goldberg: Involvement of the chaperonin *dnaK* in the rapid degradation of a mutant protein in *Escherichia coli*. *EMBO J* 11, 71-77 (1992)
306. Kandror,O., L. Busconi, M. Sherman & A.L. Goldberg: Rapid degradation of an abnormal protein in *Escherichia coli* involves the chaperones GroEL and GroES. *J Biol Chem* 269, 23575-23582 (1994)
307. Kandror,O., M. Sherman, M. Rhode & A.L. Goldberg: Trigger factor is involved in GroEL-dependent protein degradation in *Escherichia coli* and promotes binding of GroEL to unfolded proteins. *EMBO J* 14, 6021-6027 (1995)
308. Kandror,O., M. Sherman & A. Goldberg: Rapid degradation of an abnormal protein in *Escherichia coli* proceeds through repeated cycles of association with GroEL. *J Biol Chem* 274, 37743-37749 (1999)
309. Seol,J.H., S.J. Yoo, D.H. Shin, Y.K. Shim, M.S. Kang, A.L. Goldberg & C.H. Chung: The heat-shock

## Structure and function of proteasomes

protein HslVU from *Escherichia coli* is a protein-activated ATPase as well as an ATP-dependent proteinase. *Eur J Biochem* 247, 1143-1150 (1997)

310. Missiakas, D., F. Schwager, J.-M. Betton, C. Georgopoulos, S. Raina & J.M. Betton: Identification and characterization of HslV and HslU (ClpQ ClpY) proteins involved in overall proteolysis of misfolded proteins in *Escherichia coli*. *EMBO J* 15, 6899-6909 (1996)

311. Kanemori, M., K. Nishihara, H. Yanagi & T. Yura: Synergistic roles of HslVU and other ATP-dependent proteases in controlling in vivo turnover of sigma32 and abnormal proteins in *Escherichia coli*. *J Bacteriol* 179, 7219-7225 (1997)

312. Khattar, M.M.: Overexpression of the *hslVU* operon suppresses SOS-mediated inhibition of cell division in *Escherichia coli*. *FEBS Lett* 414, 402-404 (1997)

313. Andersson, M., J. Sjostrand & J.O. Karlsson: Differential inhibition of three peptidase activities of the proteasome in human lens epithelium by heat and oxidation. *Exp Eye Res* 69, 129-138 (1999)

314. Knipfer, N. & T.E. Shrader: Inactivation of the 20S proteasome in *Mycobacterium smegmatis*. *Mol Microbiol* 25, 375-383 (1997)

315. Geier, E., G. Pfeifer, M. Wilm, M. Lucchiari-Hartz, W. Baumeister, K. Eichmann & G. Niedermann: A giant protease with potential to substitute for some functions of the proteasome. *Science* 283, 978-981 (1999)

316. Wu, W.F., Y. Zhou & S. Gottesman: Redundant *in vivo* proteolytic activities of *Escherichia coli* Lon and the ClpYQ (HslUV) protease. *J Bacteriol* 181, 3681-3687 (1999)

317. Macario, A.J., M. Lange, B.K. Ahring & E.C. de Macario: Stress genes and proteins in the archaea. *Microbiol Mol Biol Rev* 63, 923-967 (1999)

318. Trent, J.D., M. Gabrielsen, B. Jensen, J. Neuhard & J. Olsen: Acquired thermotolerance and heat shock proteins in thermophiles from the three phylogenetic domains. *J Bacteriol* 176, 6148-6152 (1994)

319. Ruepp, A., C. Eckerskorn, M. Bogyo & W. Baumeister: Proteasome function is dispensable under normal but not under heat shock conditions in *Thermoplasma acidophilum*. *FEBS Lett* 425, 87-90 (1998)

320. Doolittle, W.F., W.L. Lam, L.C. Schalkwyk, R.L. Charlebois, S.W. Cline & A. Cohen: Progress in developing the genetics of the halobacteria. *Biochem Soc Symp* 58, 73-78 (1992)

321. Tumbula, D.L. & W.B. Whitman: Genetics of methanococcus: possibilities for functional genomics in archaea. *Mol Microbiol* 33, 1-7 (1999)

**Key Words:** Archaea, Proteasome, PAN, AAA ATPase, HslV, Protease, Chaperones, Stress Response, Review

**Send correspondence to:** Julie Maupin-Furlow, Department of Microbiology and Cell Science, University of Florida, Gainesville, FL 32611-0700. Tel: 352-392-4095 Fax: 352-392-5922 E-mail: jmaupin@ufl.edu

This manuscript is available on line at:

<http://www.bioscience.org/2000/d/furlow/fulltext.htm>